

STORM 

TECHNICAL SERVICES FOR
EVENTS, THEATRE, MUSIC,
EXHIBITION, FILM & TV



Lighting



Sound



Video



Rigging



Cable & Distro



Set & Stage

01483 757211

[HIRE@STORMLIGHTING.CO.UK](mailto:hire@stormlighting.co.uk)

[WWW.STORMLIGHTING.CO.UK](http://www.stormlighting.co.uk)



R10

3-way precision point source loudspeaker

Product User Manual
v3.1 April 2024



emacoustics

liberating audio

Contents

DECLARATIONS OF CONFORMITY.....	4
1.0 - Introduction	5
Unpacking	5
2.0 - R10 & Accessories	6
R10	6
FC-R10h	6
FC-R10v	7
VFA-R10	7
Reference Series Stand Adapter	7
Cradle stand adapter.....	7
2.1 - Determining the installed waveguide	8
2.2 - Rotating the MHF waveguide	9
2.3 - Changing the MHF waveguide.....	10
3.0 - Simulation.....	11
Ease Focus 3	11
4.0 - Safety Considerations	12
General Considerations in use	12
Personal Injury.....	12
Stand Mounting.....	12
Ground Stacking.....	13
Rigging and Suspension.....	13
Secondary Safeties.....	14
Safety Inspections.....	14
Material Damage from Magnetism	14
5.0 - Rigging & Mounting Options	15
5.1 - R10 Cabinet Overview	15
5.2 - Using the FC-R10v	16
5.3 - Using the FC-R10h	17
5.3.1 - Drop height adjustment on the FC-R10h	17
5.4 - Using the VFA-R10	18
5.4.1 - Angle adjustment with the VFA-R10.....	19
5.5 - Using the Reference Series Stand Adapter	19

5.6 - Using the Cradle Stand Adapter	20
5.7 - Safety Points	20
6.0 - Powering the System.....	21
6.1 - Amplifier and Processing Requirements	21
6.1.1 - Connections	21
6.1.3 - Amplifier Requirements	22
6.1.4 - Processing Requirements.....	22
6.2 - Presets and Settings	23
6.2.1 - Standard R10 presets	23
6.2.2 - Geometric Delay.....	23
6.2.3 - Applying EQ	23
6.3 - Use with the DQ Series Advanced System Amplifiers	24
6.3.1 - Connections	24
6.3.2 - Preset Recall.....	24
6.4 - System Connectivity.....	25
6.4.1 - Cable Length and Specification.....	25
6.4.2 - Crossover Cable Use	25
7.0 - Servicing Information.....	26
7.1 - R10: Removing the grille	26
7.2 - R10: Removing the LF drive unit.....	27
7.3 - R10: Removing the HF drive unit	29
Appendix A - Technical Specifications.....	30
R10 3-way precision passive point source loudspeaker	30
Appendix B - Technical Drawings	31
Appendix C - Spare Parts List.....	37
Appendix D - Warranty Information.....	38
Limited Warranty	38
Warranty Coverage	38
Returning your EM Acoustics loudspeaker.....	38

DECLARATIONS OF CONFORMITY



This declaration applies to:

10M603 - R10 compact 3-way precision passive point source loudspeaker

This declaration also applies to all product variants, provided that they conform to the original technical specification and have not been subject to any non-factory modifications.

We herewith declare that the products listed above are in conformity with the provisions of the respective directives including all applicable amendments.

Details of the applicable declarations can be downloaded from our website www.emacoustics.co.uk on the individual product pages.

WEEE Declaration



This product and its packaging constitute the applicable product according to the WEEE directive. Please ensure that at the end of the working life of this product, it is disposed of sensibly in accordance with local and national recycling regulations.

The packaging supplied with this product is recyclable.

Please retain all packaging, however if disposing of this packaging please ensure that you comply with local recycling regulations.

WEEE Producer Registration Number WEE/HH0101WU.

1.0 - Introduction

Thank you for purchasing this highly acclaimed product from EM Acoustics. This product has been designed and rigorously tested to give you the utmost in sonic performance and many years of reliable, trouble-free operation. Please take the time to read this user manual thoroughly to ensure you get the best performance from your system and to ensure you set it up correctly and safely. If you have any questions or are in any doubt whatsoever about any aspect of your new product, please do not hesitate to contact us directly or your local EM Acoustics representative.

The R10 is a revolutionary 3-way loudspeaker, intended for a wide variety of audio applications - from theatrical use through to corporate A/V, speech reinforcement and even medium scale live music reinforcement. The compact and slim enclosure houses a pair of 10" neodymium LF drive units and a 4"/2.5" diaphragm, 1.4" exit annular MHF compression drive unit coupled to a rotatable constant coverage waveguide. Two waveguides are supplied with the R10 - 80° x 50° fitted as standard (labelled "narrow") and 110° x 50° supplied loose (labelled "wide"). These three drive units are linked with a completely new type of passive crossover network, designed from the ground up to work in conjunction with the FIR (Finite Impulse Response) processing in the DQ Series advanced system amplifiers. This means the R10 exhibits a level of frequency and phase response previously unattainable, all within a lightweight and discreet physical package.

This manual contains all the information you should need on topics of set up, amplifier connection and basic service. If you feel we have missed anything, or you have a question not covered by this manual, please visit our website www.emacoustics.co.uk and send us a message or give us a call - we're only too happy to help.

Unpacking

Please take care when unpacking your loudspeaker system. Once unpacked, please inspect each enclosure thoroughly for any transit damage and in the case of any damage please notify your carrier immediately. It is the responsibility of you, the consignee, to instigate any claim. Please retain all original packaging in case of future re-shipment.

2.0 - R10 & Accessories

R10

3-way precision point source loudspeaker

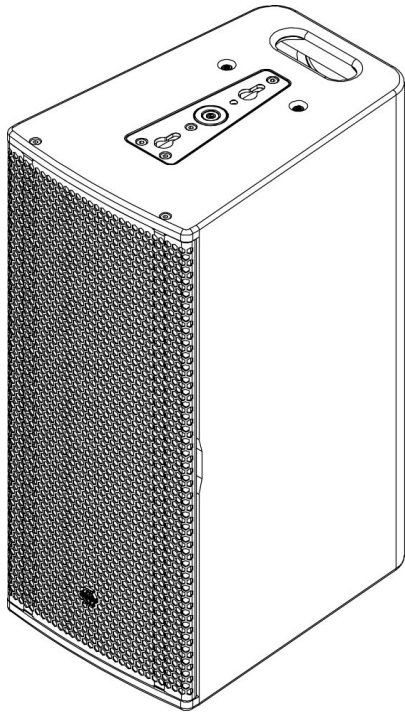

FEATURES & BENEFITS

- Signature EM Acoustics “maximum headroom” design approach ensures consistency of performance regardless of SPL level.
- Quick-release flying system for touring applications.
- Multiple M10 threaded flying points for temporary and permanent installation.
- Enclosure coated with 3-step polyurethane process - ensuring the cabinets are not only weather resistant but more resilient to impact damage.
- Various rigging accessories available.
- Connections on NL4.
- Single DQ Series amplifier channel required.

KEY SPECIFICATIONS

ENCLOSURE TYPE:	3-way passive, reflex loaded
DRIVE UNITS:	LF: 2 x 10" / MHF: 1.4" exit coaxial annular driver
FREQUENCY RESPONSE:	60Hz - 20kHz +/-3dB
NOMINAL DISPERSION:	80° x 50° rotatable (narrow) 110° x 50° rotatable (wide)
MAXIMUM SPL:	130dB continuous, 136dB peak
NOMINAL IMPEDANCE:	8 ohms
DIMENSIONS (HxWxD):	700 (27.6) x 306 (12) x 430 (16.9) mm/(ins)
NET/SHIPPING WEIGHT:	31/36kg (68.2/79.2lbs)

FC-R10h

Horizontal flying cradle

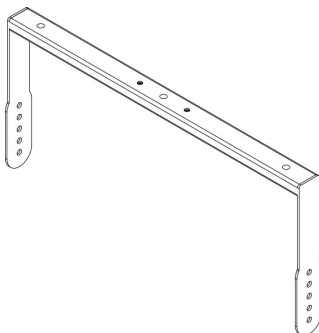

The FC-R10h is a simple and effective means of mounting the R10 horizontally in both temporary and permanent applications.

It is secured to the cabinet by means of two M10 hand knobs into the top and bottom of the loudspeaker to mount it in a landscape format. Multiple 13mm diameter holes are provided for attachment in installation or via a hook clamp or similar. Two M10 threaded fittings are provided to allow mounting onto a 35mm loudspeaker stand using the Cradle Pole Adapter.

The FC-R10h is designed to support one single R10 loudspeaker.

Weight (including fixings) 4kg / 8.8lbs

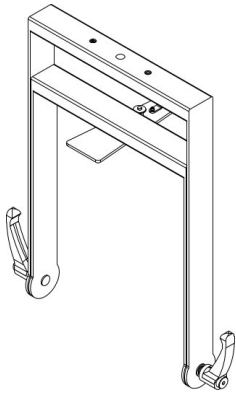
FC-R10v**Vertical flying cradle**

The FC-R10v is a simple and effective means of mounting the R10 vertically in both temporary and permanent applications.

It is secured to the cabinet by means of a quick-release keyhole plate in the top of the loudspeaker to mount it in a portrait format. A single 13mm diameter fixing point is provided at the top of the outer yoke for attachment either in installations or via a hook clamp or similar. Two M10 threaded fittings are provided to allow mounting onto a 35mm loudspeaker stand using the Cradle Pole Adapter.

The FC-R10v is designed to support one single R10 loudspeaker.

Weight (including fixings) 6.7kg / 14.8lbs

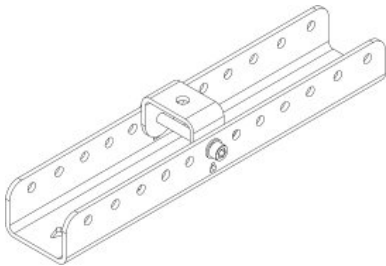
VFA-R10**Variable Angle Flying bracket**

The VFA-R10 is a simple and effective means of mounting the R10 vertically in both temporary and permanent applications.

The VFA-R10 uses the centre of gravity of the R10 to determine the hanging angle, with variation from +25° to -30° depending on the pickup hole chosen.

The VFA-R10 is designed to mount to an eyebolt or hook clamp/half coupler for pickup.

The VFA-R10 is designed to support one single R10 loudspeaker.

Weight (including fixings) 3.1kg / 6.8lbs

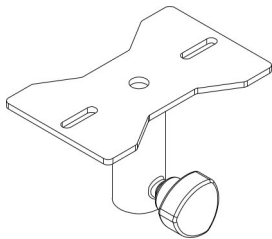
Reference Series Stand Adapter**Simple stand mounting**

For simple mounting on a loudspeaker stand or pole, the R10 is packaged with a bolt-on 35mm adapter and appropriate fixings. The adapter attaches via the two M8 threaded points in the bottom of the R10 using the supplied fixings.

The stand adapter is designed to support one single R10 loudspeaker.

Weight (including fixings) 0.75kg / 1.7lbs

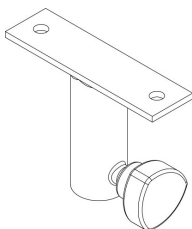
Cradle stand adapter**Stand mounting with flying cradles**

To allow the mounting of the R10 on a stand yet keeping the ability to tilt the loudspeaker, the R10 cradles can both be used with this optional accessory. Using the supplied M10 fixings, the cradle stand adapter attaches to the flying cradle allowing it to be mounted directly onto a loudspeaker stand.

The cradle pole adapter is designed to support one single R10 loudspeaker.

Weight (including fixings) 0.5kg / 1.1lbs

2.1 - Determining the installed waveguide and orientation

There are two waveguides supplied with the R10 loudspeaker, and each waveguide is rotatable meaning there are four possible waveguide dispersion combinations.

To make identifying which waveguide is installed simple and quick, there is a viewing recess in the enclosure on each side where the grille meets the enclosure woodwork.

Simply look in this small recess, and the identifying label will show which waveguide is fitted and its orientation.

The 80x50 waveguide has blue indicator labels, and the wider 110x50 waveguide has red indicator labels.

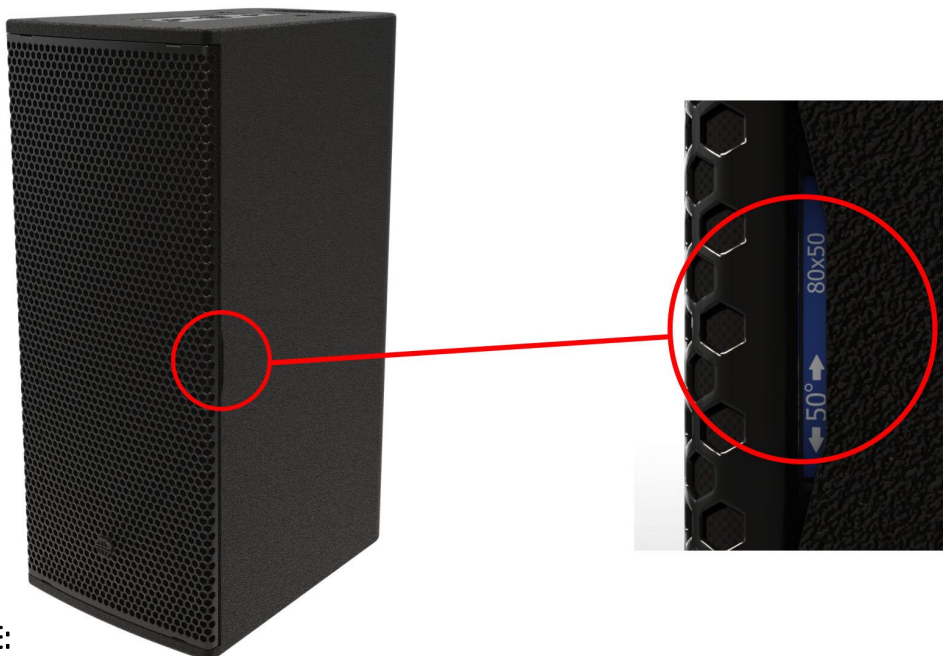

NOTE:

The arrows indicate the dispersion in the direction shown - in the example above, the label indicates that the 80° x 50° horn is fitted and is oriented so it is 50° in the vertical plane (and therefore 80° in the horizontal plane).

By default, the R10 ships from the factory with the 80x50 waveguide fitted, and the dispersion pattern 80° horizontal x 50° vertical when the loudspeaker is in a portrait format. In this format, the label showing in the viewing recess would be:



2.2 - Rotating the MHF waveguide

The high frequency waveguide of the R10 can be easily rotated to provide appropriate dispersion in both portrait and landscape formats.

By default, the R10 ships from the factory with the dispersion pattern 80° horizontal x 50° vertical when the loudspeaker is in a portrait format.

To rotate the waveguide:

1. Use a 4mm Allen key to remove the four M6 countersunk machine screws that secure the grille (two top, two bottom) and lift the grille clear.
2. Using a 4mm Allen key, remove the two M6 x 35mm button head socket screws that secure the waveguide.
3. Lift the waveguide up from the enclosure to rotate through 90 degrees to the desired orientation - the label on the side of the waveguide denotes the dispersion.
4. Once in the correct orientation, replace the M6x35 button head socket screws and retighten.
5. Replace the grille.

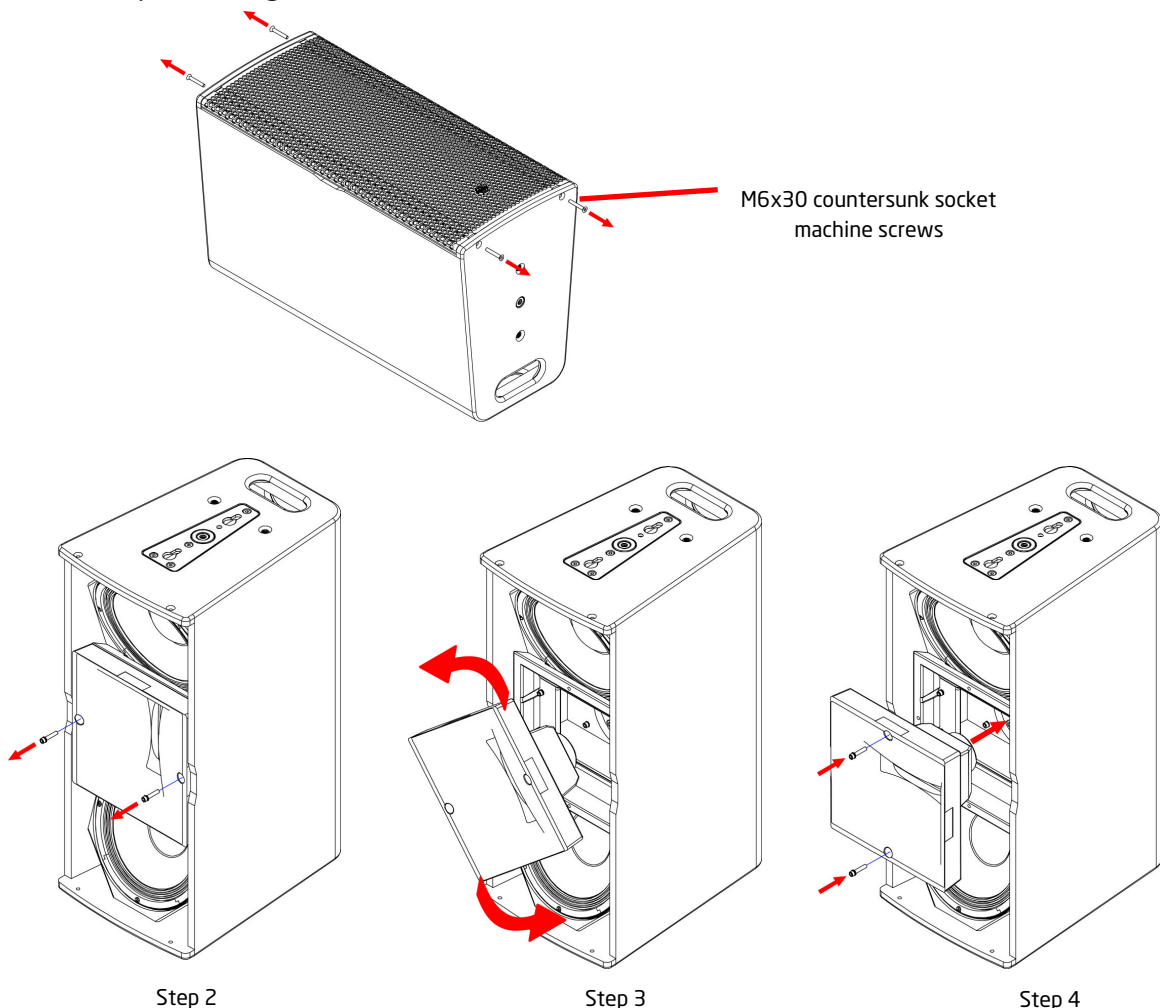

2.3 - Changing the MHF waveguide

The R10 is supplied with two waveguides for maximum flexibility - a narrow dispersion ($80^\circ \times 50^\circ$) and a wide dispersion ($110^\circ \times 50^\circ$).

By default, the R10 ships from the factory with the dispersion pattern 80° horizontal x 50° vertical when the loudspeaker is in a portrait format.

To change the waveguide:

1. Follow steps 1 & 2 in chapter 2.2 to remove the grille and the waveguide securing bolts.
2. Lift the waveguide clear of the enclosure - the drive unit is secured internally to the loudspeaker, and as such the waveguide is free to be removed once the bolts are removed.
3. Fit the alternative waveguide into the enclosure - note that there is a precise fit at the throat of the waveguide with the aluminium mounting plate in the enclosure, so ensure this is located properly before attempting to retighten the bolts.
4. With the waveguide in the correct orientation, replace the M6x35 button head socket screws and retighten.
5. Replace the grille.

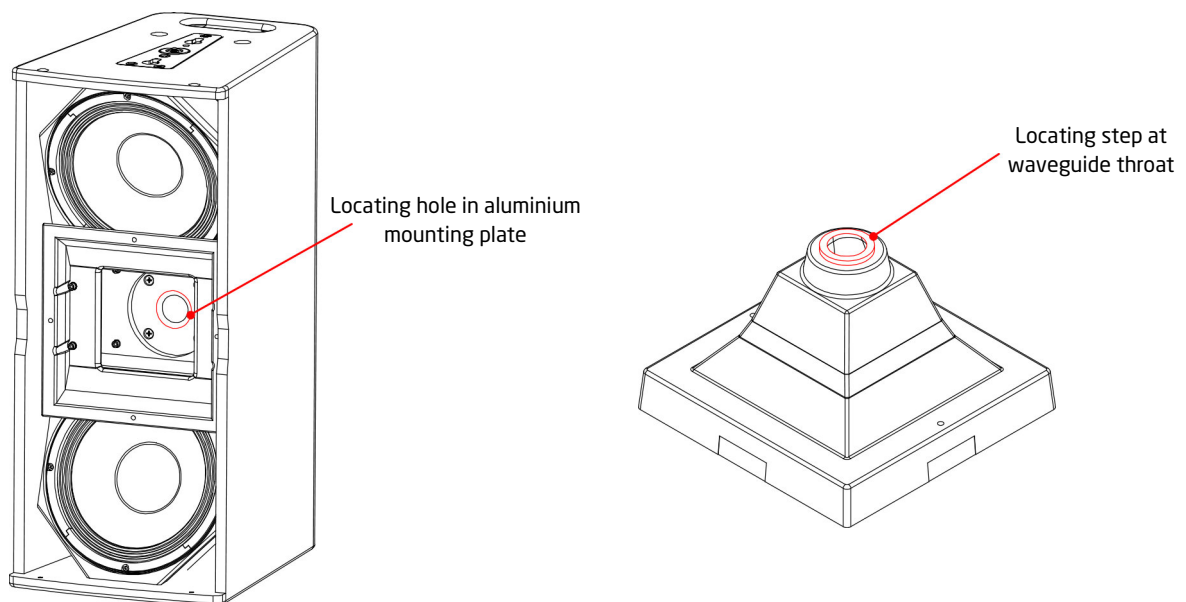

3.0 - Simulation

Ease Focus 3

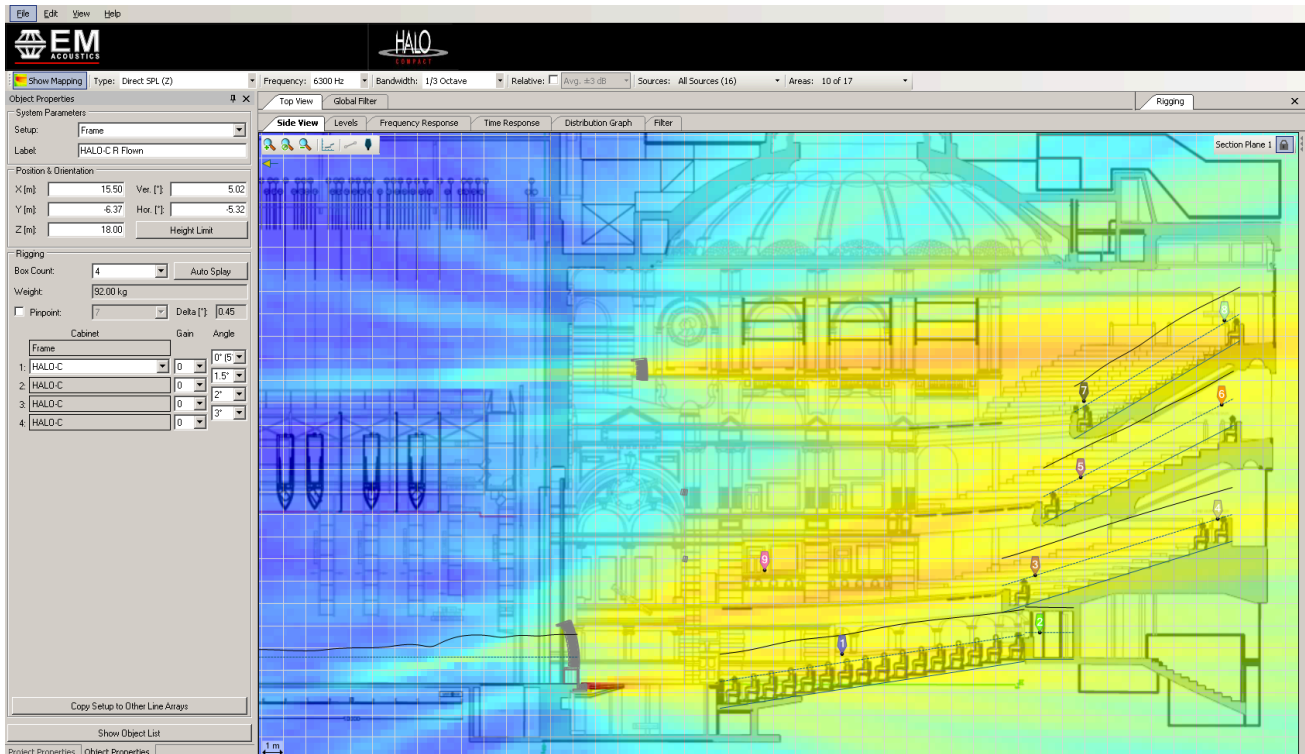

For acoustic reasons it is advised that users familiarize themselves with Ease Focus 3 - this system provides the user with accurate simulations for setting up R10 loudspeakers.

Ease Focus 3 can be downloaded for free from the AFMG website at <http://focus.afmg.eu> and is currently available as a stand-alone application for Windows (XP or Higher) only. It can also be downloaded directly from the [EM Acoustics website](#) with all the current product files embedded.

Tutorials for Ease Focus 3 are available from with the application itself.

For training on the design and implementation of R10 loudspeakers including the specific use of Ease Focus 3, please contact your local distributor.

4.0 - Safety Considerations

General Considerations in use

Loudspeaker systems are potentially dangerous objects if used incorrectly. Please ensure that you read this section fully, and contact EM Acoustics or your local dealer should you be in any doubt over correct operation procedures.

Personal Injury

Never stand in the immediate vicinity of loudspeakers when in use at high level. Professional loudspeaker systems are capable of producing sound pressure levels which can cause permanent damage to human hearing. Levels in excess of 90dB can cause hearing damage if people are exposed to them over a long period of time, so care and attention must be used for both staff and audience members.

When deploying loudspeaker systems on the ground or when flown, please take careful note of the following important safety considerations:

- Only use accessories and flying hardware supplied or approved by EM Acoustics for flying or transporting loudspeaker systems. Pay close attention to specific instructions, especially those considering maximum load capabilities as detailed in the appropriate user manuals or on the legend labels on the accessories themselves.
- Ensure all additional accessories, fasteners and secondary safeties are of an appropriate size, working load limit and safety factor.
- All loudspeakers and accessories should be regularly inspected for signs of wear and tear, and any damaged parts should be replaced.
- All load bearing parts and assembly bolts on accessories should be regularly checked to ensure they are tight and not worn.

Stand Mounting

When mounting loudspeakers on a stand, please take note of the following important considerations:

- Ensure your stand height is locked off and the tripod legs are positioned so as to be stable.
- Check the weight loading of your stands before attempting to mount the loudspeaker.
- Do not stack a second loudspeaker on top of the stand-mounted one.
- Ensure cables are run so as to leave enough slack to enable neat wiring, and thus reduce the risk of the speaker being pulled over. Loose cables should be covered or taped down wherever possible to reduce trip hazards.
- If stands are being used outdoors, it may be necessary to add ballast to the base of the stand to prevent it toppling over.
- When using poles on top of subwoofer systems, please observe similar precautions.

Ground Stacking

- Ensure that the floor or stage surface can withstand the weight of the system.
- Wherever possible, avoid high stacks and use ratchet straps to secure loudspeakers together. Please also remember that vibrations from subwoofer systems can shake other loudspeakers out of place, which may present a toppling hazard. The use of ratchet straps and non-slip material is recommended to prevent this.

Rigging and Suspension

Please see Chapter 5 for further information on the detailed rigging options for your loudspeaker system.

WARNING: The overhead suspension of loudspeakers is a very serious issue with potentially lethal consequences should anything go wrong. Rigging should only be carried out by experienced personnel following safe working practice. Should you be in any doubt whatsoever, please contact your local dealer who will be able to refer you to a suitable rigging company.

To ensure the highest standards of safety, the following information on array assembly must be exactly followed and understood.

Only use EM Acoustics recommended rigging hardware and accessories, which are specifically designed for the purpose. Do not use these accessories for any other loudspeaker system - the components are specifically designed to work with this product and are not interchangeable with any other EM Acoustics loudspeaker product (unless where specifically stated) or any other loudspeaker system. The use of EM Acoustics accessories with other manufacturers' systems may compromise the safety standards and EM Acoustics is in no way liable for any loss, damage or injury caused by such practice.

Do not modify or alter the R10 loudspeaker or accessories, nor use them in any way other than that described in this manual. Rigging components supplied with the R10 are in no way interchangeable and should not be used as such.

The component parts of the R10 and its accessories should only be assembled in the manner described in this manual, using the fasteners and fixings stated herein. The use of fasteners and methods of assembly not described in this manual may result in an unsafe assembly and as such EM Acoustics will not be responsible for any loss, damage or injury caused by such practice. Welding, drilling or any other means of modifying any part of the flying hardware or permanently fixing components to each other is strictly forbidden.

Rigging assemblies must only be assembled using the appropriate parts and fixings as described in this manual, explicitly following the assembly instructions given herein. Rigging components must only be fixed to the R10 loudspeaker, using the correct cabinet location points, assembly methods and fasteners specifically described within this manual.

Walls, floors and ceilings must be capable of supporting the actual load placed upon them. The rigging hardware must be safely and securely fixed to both the loudspeaker system and the supporting structure.

Secondary Safeties

It is imperative that all loudspeakers flown in any given environment should be provided with a second, independent and properly rated safety suspension point in addition to the principle load bearing means of suspension. Steel wire ropes or steel chains of an approved construction and load rating only may be used as secondary safeties. Plastic covered steel chains may not be used as secondary safeties under any circumstances. Also ensure that all local and national laws are complied with when determining your primary and secondary suspension points.

Safety Inspections

Carefully inspect all flying system components prior to use for defects or signs of damage prior to installing or mounting your loudspeaker. If any components damaged or **you suspect them to be damaged, DO NOT USE THEM.**

Regular scheduled tests - which are much more rigorous than visual inspections - of all rigging components must also be carried out. Safety legislation, and test/inspection requirements, will vary from country to country and as such it is the user's responsibility to ensure that local regulations are adhered to. In most cases, annual independent tests & inspections carried out by a suitably approved and qualified inspector will be required.

EM Acoustics recommends detailed logbooks be kept of all inspections and load tests to ensure an accurate record is kept of the testing for each EM Acoustics rigging accessory.

When flying any loudspeaker system, always wear protective headwear, footwear and eye protection in accordance with local regulations.

Material Damage from Magnetism

Loudspeakers produce a static magnetic field at all times - even when not in use. Certain devices are susceptible to external magnetism, and as such a safe distance should be maintained to prevent damage. It is recommended that a safe distance of 0.5m (1.5ft) is maintained from loudspeakers when stored, transported and in use, from devices such as computer hard drives, magnetic media, bank cards to remove the risk of corruption. Larger distances may be required for some older cathode ray tube displays.

5.0 - Rigging & Mounting Options

5.1 - R10 Cabinet Overview

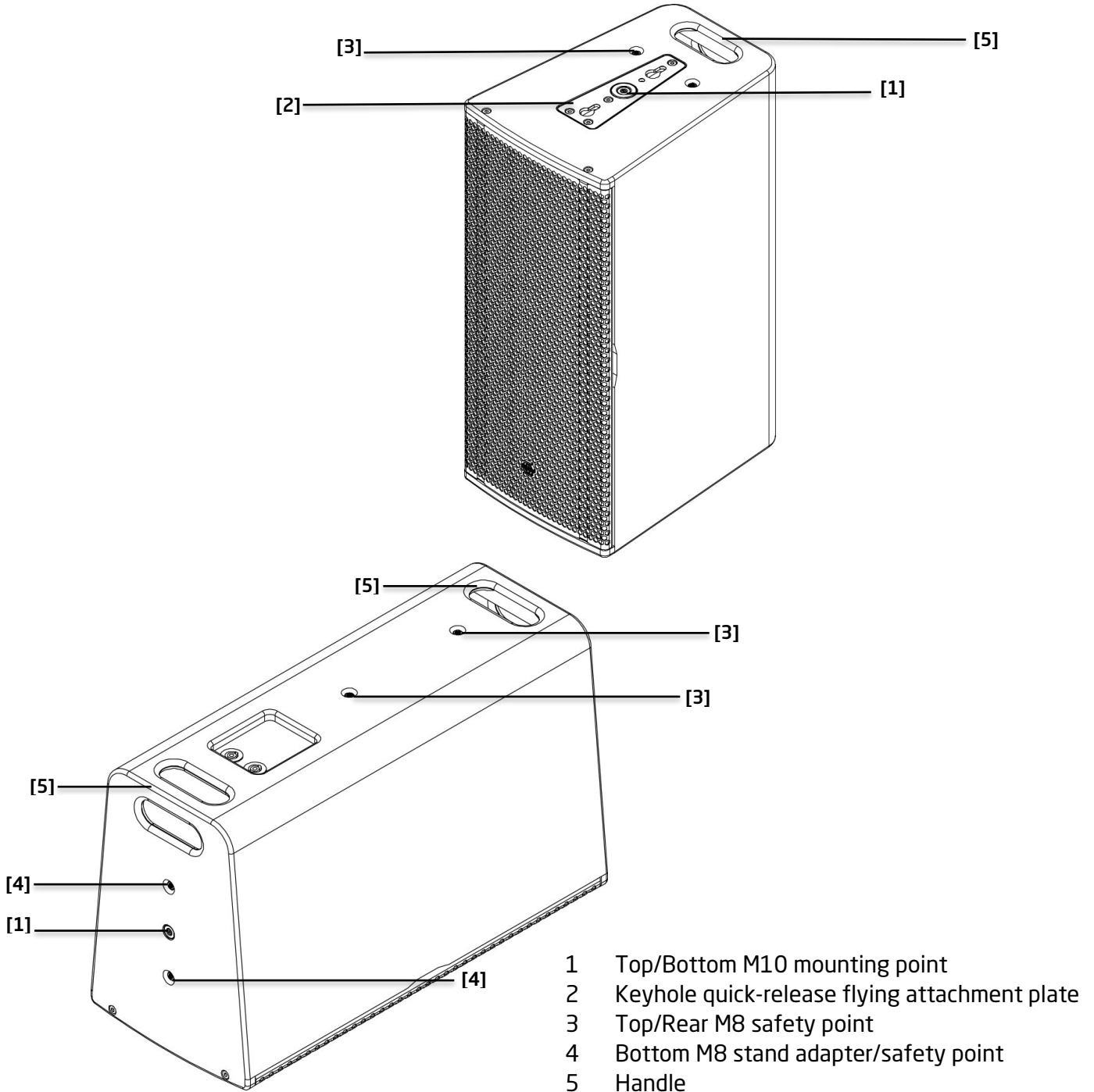

5.2 - Using the FC-R10v

The FC-R10v is intended to mount the R10 vertically - either using a hook clamp or similar from above, or a pole mount adapter to mount on a stand yet allowing enclosure tilt (see chapter 5.5). The procedure for attaching the FC-R10v to the loudspeaker is the same regardless of the mounting orientation.

The FC-R10v uses steel machined parts to bear the load, and a ball-lock quick release pin to secure the cradle in place.

Step 1

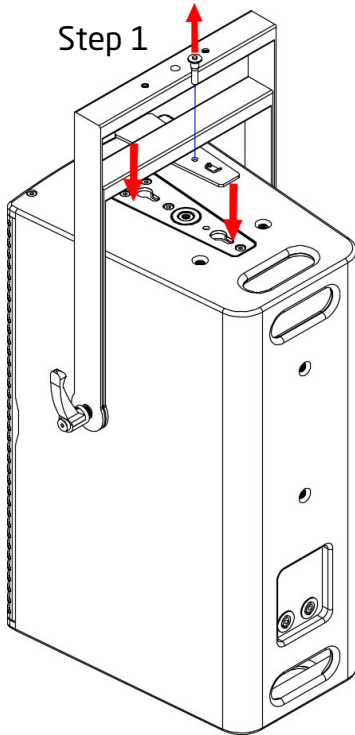

Remove the single ball-lock pin from its location in the mounting plate. Lower the FC-R10v so that the bosses underneath engage into the mounting plate.

Step 2

Slide the FC-R10v to the rear of the loudspeaker as far as it will go. Once in this position, replace the ball-lock pin to lock the cradle in place.

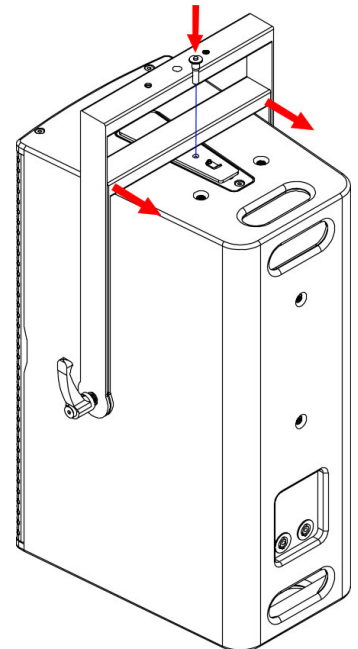

Step 3

The FC-R10v is now ready to be lifted - using a hook clamp or similar from the central pickup point on the outer yoke.

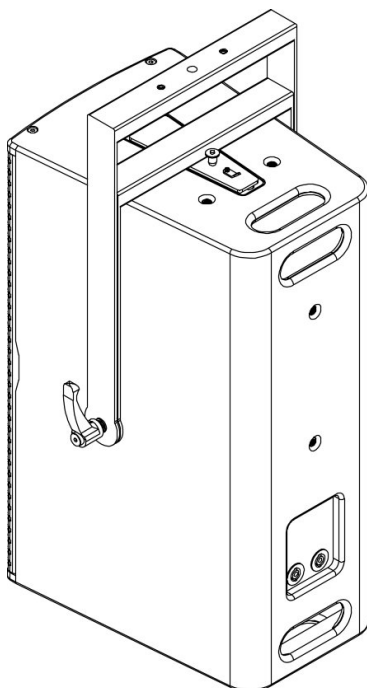

5.3 - Using the FC-R10h

The FC-R10h is intended to mount the R10 horizontally. To fit, lie the R10 on its side and line the flying cradle up with the mounting holes in the desired location (see 5.3.1 below). Secure to the R10 using the supplied M10 locking knobs.

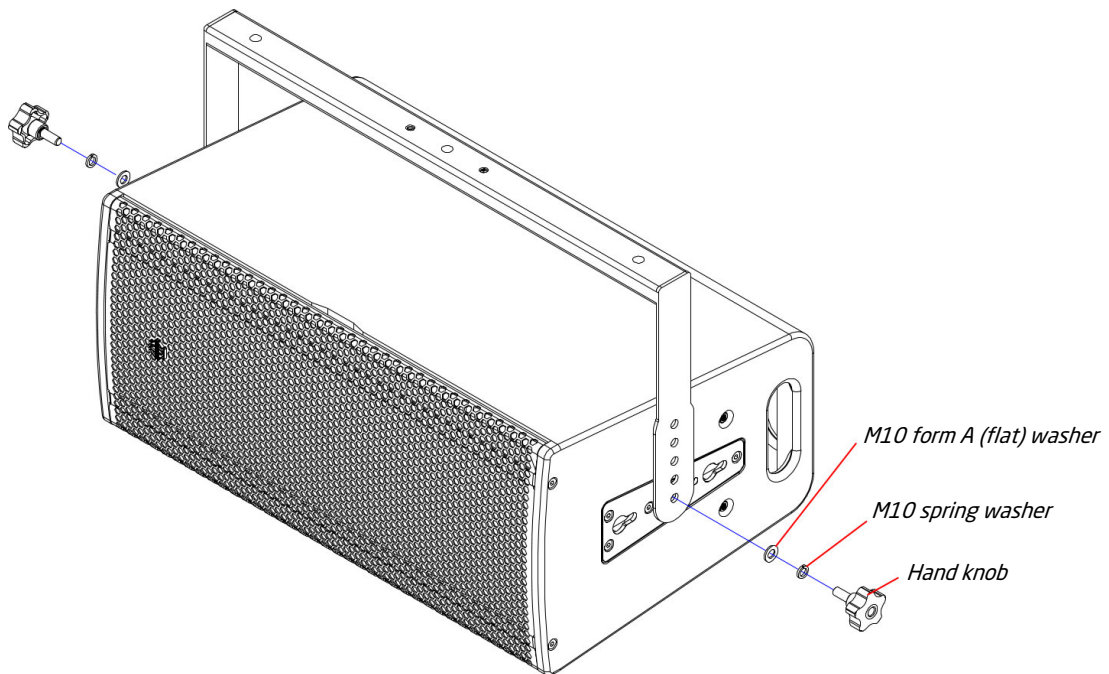

Ensure that the washers are in the correct order - form A (flat) in contact with the frame, and then the spring washer between the flat washer and the locking knob. Tighten the handles on both sides to lock the desired angle for the R10.

Always ensure that a secondary safety is used when suspending any loudspeaker.

5.3.1 - Drop height adjustment on the FC-R10h

Different location holes to secure the R10 to are provided on the FC-R10h mounting yoke. Position 1 (closest to the end of the yoke arms) allows full 360° rotation of the loudspeaker, and positions 2-5 offer a closer fit to the yoke, but with reduced rotational ability of the loudspeaker itself.

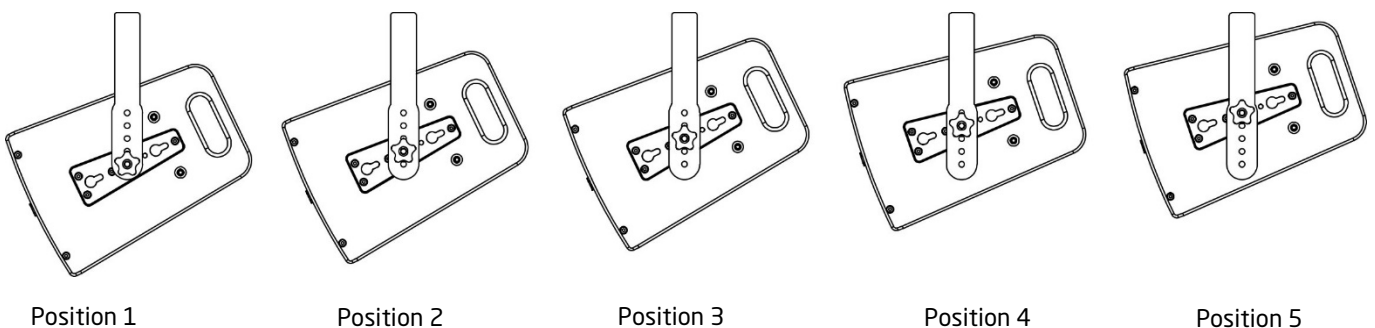

5.4 - Using the VFA-R10

The VFA-R10 is a single-point suspension bracket, designed to support a single R10 loudspeaker and uses the R10's centre of gravity to determine the up or down-tilt angle. In this way, angles from 25 degrees up-tilt to 30 degrees down-tilt can be selected in 5-degree increments. The VFA-R10 is designed to be suspended from a hook clamp/half coupler or an eye bolt through the pickup bracket.

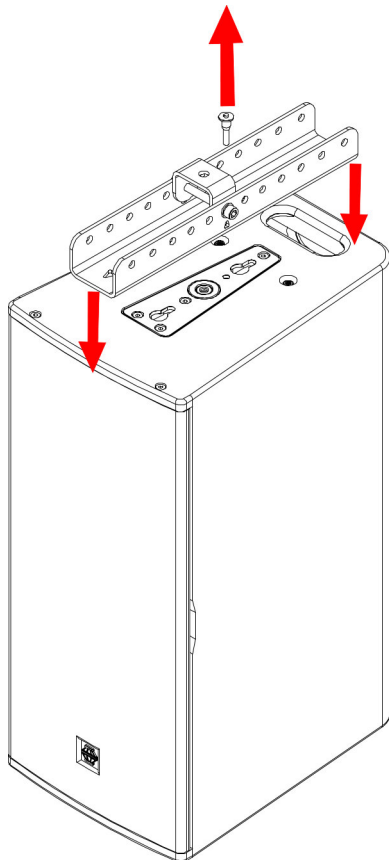

Step 1

Remove the single ball-lock pin from its location in the main bracket. Lower the VFA-R10 so that the bosses underneath engage into the mounting plate.

The laser cut arrow in the main bracket indicates the front of the bracket.

Step 2

Slide the main bracket toward the rear of the R10 as far as it will go. You can then reinstate the ball-lock pin to lock the bracket in place.

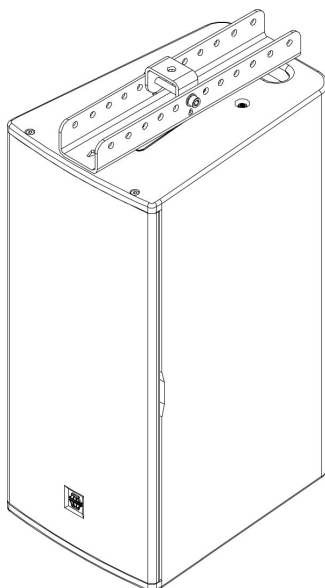
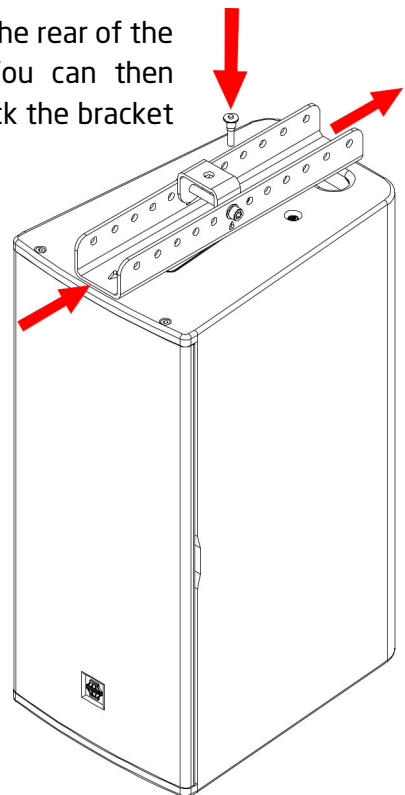

Step 3

The VFA-R10 is now ready to be lifted - using a hook clamp or similar from the central pickup point on the outer yoke.

5.4.1 - Angle adjustment with the VFA-R10

The angle that the R10 will hang at depends on the pickup hole selected. The 6th hole back from the front will hang the R10 flat, all other holes will increase the angle in 5-degree increments. In this way, the front hole will provide 25° of up-tilt, and the furthest back hole will provide 30° of down-tilt.

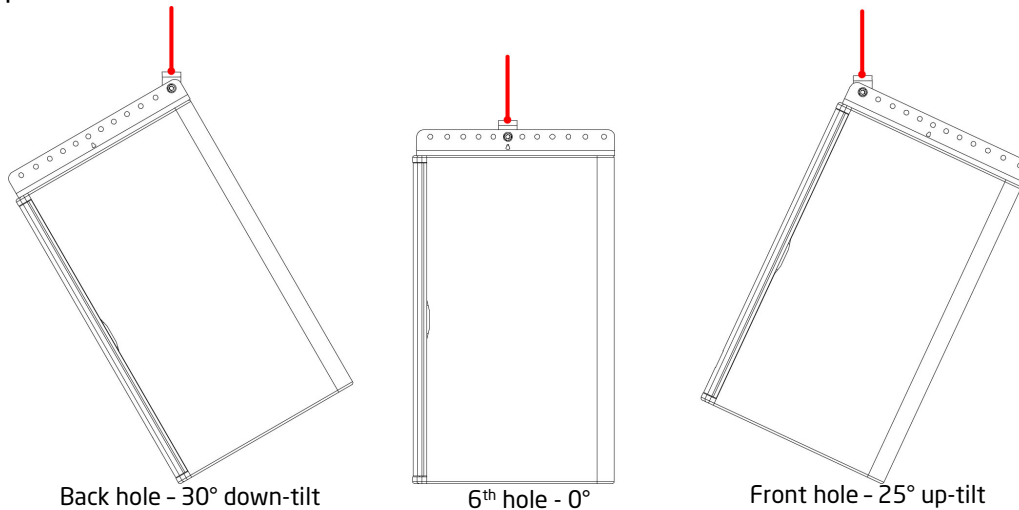

5.5 - Using the Reference Series Stand Adapter

The R10 is supplied with the Reference Series stand adapter, allowing the user to mount the R10 directly onto a standard 35mm loudspeaker stand or distance pole. To fit, simply lie the R10 on its back or stand it on its top, line the Stand Adapter up with the two M8 mounting holes on the base of the enclosure.

Secure the Stand Adapter using the supplied M8x20 socket cap bolts, with flat and spring washers. Ensure that the flat washer is in contact with the Stand Adapter, and the spring washer between the flat washer and the bolt head.

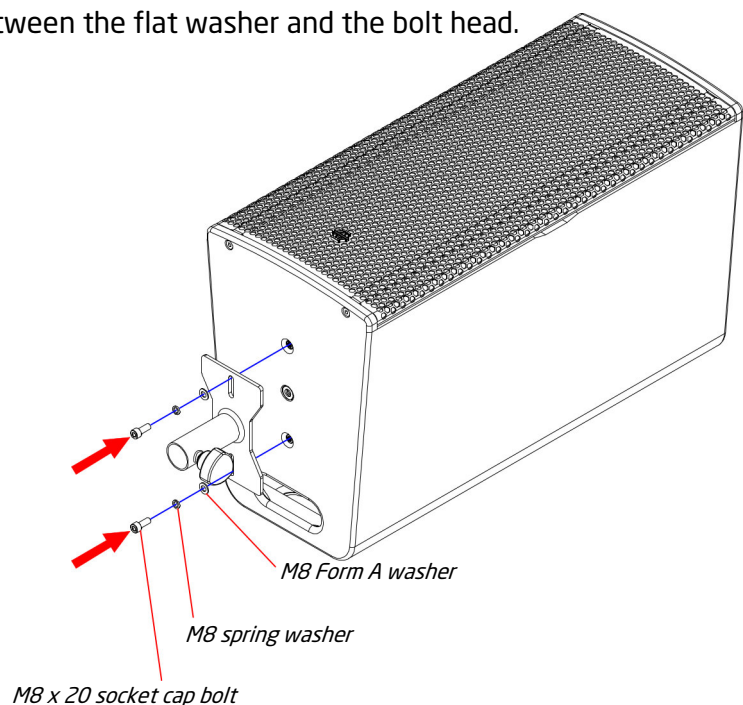

5.6 - Using the Cradle Stand Adapter

The Cradle Stand Adapter allows the use of both the FC-R10v and FC-R10h flying cradles to mount on loudspeaker stands, to give tilt as well as pan. To use, simply fit the desired flying cradle as described above, and then secure the Cradle Stand Adapter to the outer yoke of the cradle using the supplied fixings into the captive threaded fittings in the yoke.

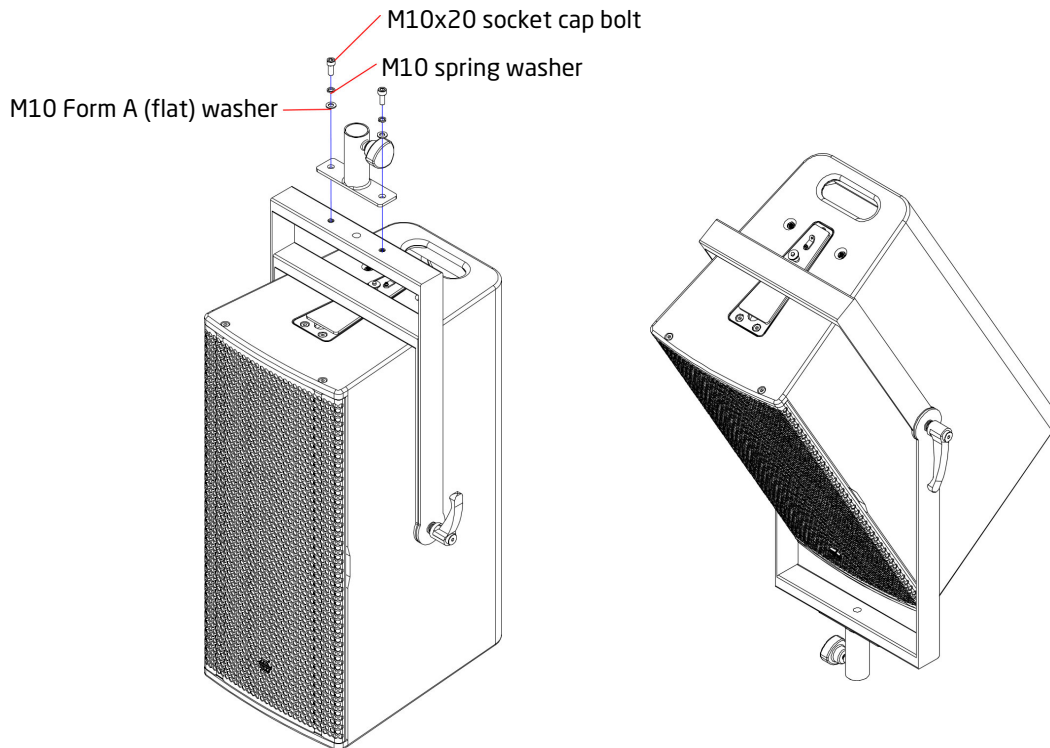

5.7 - Safety Points

Any flown loudspeaker must always have a secondary safety fitted. There are six M8 threaded points that can be used as safety points - two on the top, two on the rear, and two on the bottom. A simple M8 forged shoulder eyebolt can be screwed into this point. Safeties should always be arranged so that the loudspeaker cannot drop in the event of a primary attachment point failing so select the most appropriate safety point considering the rigging situation.

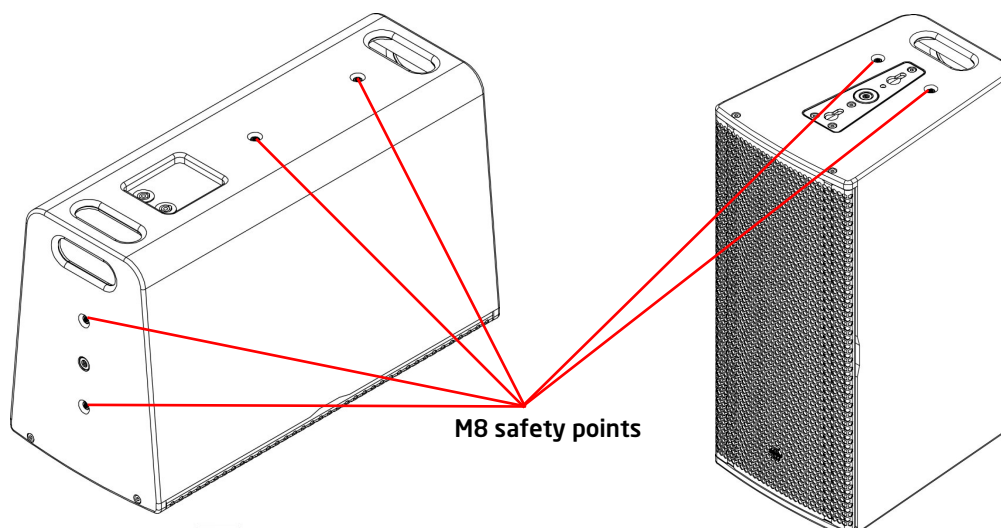

6.0 - Powering the System

The R10 makes use of FIR (Finite Impulse Response) processing, and as such requires specific proprietary DSP settings that are only available within the DQ or Di Series amplifiers, or the DSC48 system controller. These complimentary electronics packages also provide all necessary high pass, limiting and protection systems to ensure the best performance out of the R10.

The R10 should not be used with any other amplification or processing platform.

6.1 - Amplifier and Processing Requirements

6.1.1 - Connections

The R10 requires only a single amplifier channel. Inputs to the R10 enclosure are on Neutrik SpeakON NL4 as illustrated below.

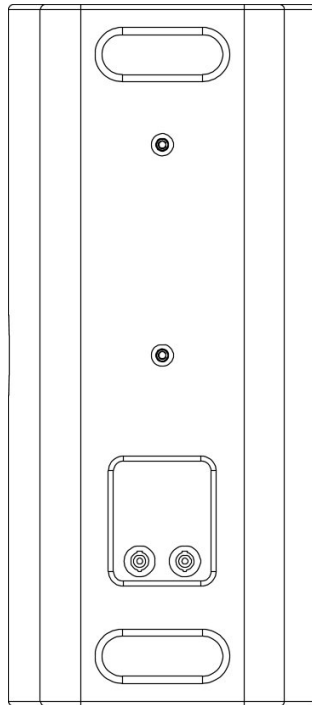

Two-core cable should be used for connecting R10 loudspeakers, and the connections are as follows:

SpeakON connection	1+	1-	2+	2-
Drive unit connection	LF +	LF -	Link Through	Link Through

6.1.3 - Amplifier Requirements

The R10 is a highly efficient loudspeaker, however appropriate available power is critical to ensure full system headroom. It is good practice to ensure that your amplifier can deliver at least double the RMS power handling of the loudspeaker to ensure full headroom, and as such the amplifier requirement is:

Product	RMS Power Handling	Recommended Min. Amplifier Power
R10	1000W @ 8 ohms	2000W @ 8 ohms

A loudspeaker is far more likely to be damaged by an under-powered amplifier working too hard, than an over-powered amplifier working well within its limits.

All of the DQ and Di Series advanced system amplifiers can be used to power the R10.

The following table shows the maximum number of R10 that can be connected per channel on the various different amplifiers:

Amplifier	Recommended R10/channel (for full headroom)	Max R10/channel (*at reduced max SPL)
DQ6	1	2*
DQ10	1	2*
DQ20	2	2
Di06	Not recommended	1*
Di10	Not recommended	1*
Di20	1	2*

6.1.4 - Processing Requirements

Whilst the R10 is a passive loudspeaker, it is designed to be part of a system in conjunction with a DQ or Di Series amplifier. These intelligent amplifiers provide not only protective settings to prevent damage to your R10 loudspeaker, but also makes use of the state-of-the-art Finite Impulse Response (FIR) processing. Using the R10 without a DQ or DI Series amplifier will produce unpredictable performance and must not be done.

6.2 - Presets and Settings

6.2.1 - Standard R10 presets

When used with a DQ or DI Series amplifier R10 loudspeakers require only a single amplifier channel, and as such the preset recalled will only require one output from your amplifier.

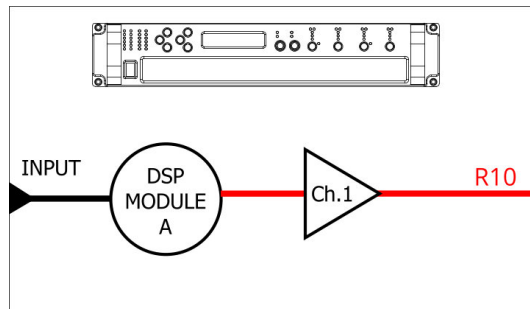

Two standard presets are in the EM Acoustics preset library - one for the narrow waveguide, and one for the wide. Whilst the difference is subtle, please ensure the correct preset is loaded for the waveguide that has been installed for optimum performance.

6.2.2 - Geometric Delay

Appropriate delay will need to be applied to account for physical location differences between different elements of your system - for example time-aligning subwoofers to the main system. The use of SMAART or similar can make this task a great deal simpler and faster.

6.2.3 - Applying EQ

The presets are intended to be a starting point for your system and will almost certainly require tuning on-site dependent on room characteristics, the rest of your system design and the system voicing you are aiming for. The R10 is designed with a significant amount of system headroom, so applying EQ is perfectly acceptable within sensible limits.

6.3 - Use with the DQ Series Advanced System Amplifiers

The R10 is designed to be used with DQ or Di Series advanced system amplifiers, as not only are they state-of-the-art amplifiers, but the onboard DSP provides appropriate processing to allow the R10 to perform as intended. Please refer to the relevant amplifier User Manual for detailed information on using the amplifiers and the System Engineer software.

6.3.1 - Connections

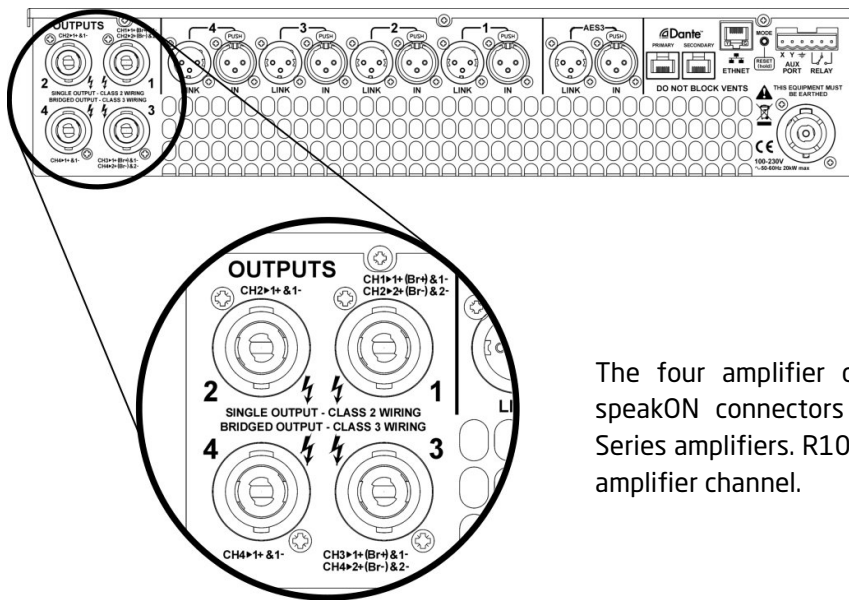

The four amplifier channels appear on four speakON connectors on the rear of the DQ Series amplifiers. R10 loudspeakers require one amplifier channel.

6.3.2 - Preset Recall

The R10 presets are pre-installed on EM Acoustics' amplifiers (ensure you have the latest preset library installed on your amplifier), and as such can be used following the normal preset recall procedure. The presets available are:

R10-N.full Narrow waveguide R10 preset

R10-W.full Wide waveguide R10 preset

As mentioned above, these presets are intended to be a starting point and additional work may be required depending on the venue, the style of content and the end result you are looking for.

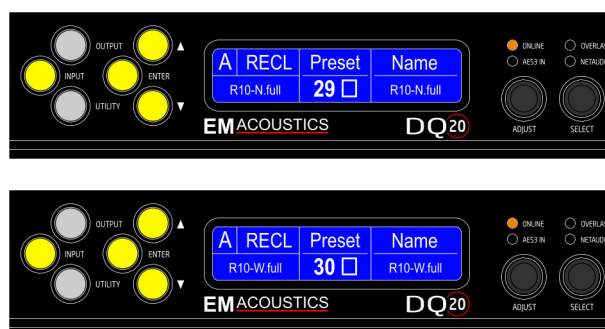

6.4 - System Connectivity

6.4.1 - Cable Length and Specification

All cables add to the system impedance, and as such careful selection is required depending on your amplifier setup and overall system impedance. Cables with a cross sectional area of less than 2.5mm² should not be used. Recommended maximum cable lengths are given below:

Conductor Area	Maximum Recommended Cable Length		
	2 ohms	4 ohms	8 ohms
2.5mm ² (14 AWG)	15m	30m	60m
4.0mm ² (12 AWG)	20m	40m	80m
6.0mm ² (10 AWG)	30m	60m	120m

6.4.2 - Crossover Cable Use

The use of a pin-swap or “crossover” cable can allow for neater cable solutions when sending different amplifier signals to the same location. Because pins 2+/2- are linked through inside all EM Acoustics loudspeakers, using a 4-core cable to one loudspeaker (carrying two different signals) allows a crossover cable to be used to link out of the first loudspeaker into another, thereby feeding it from a separate signal.

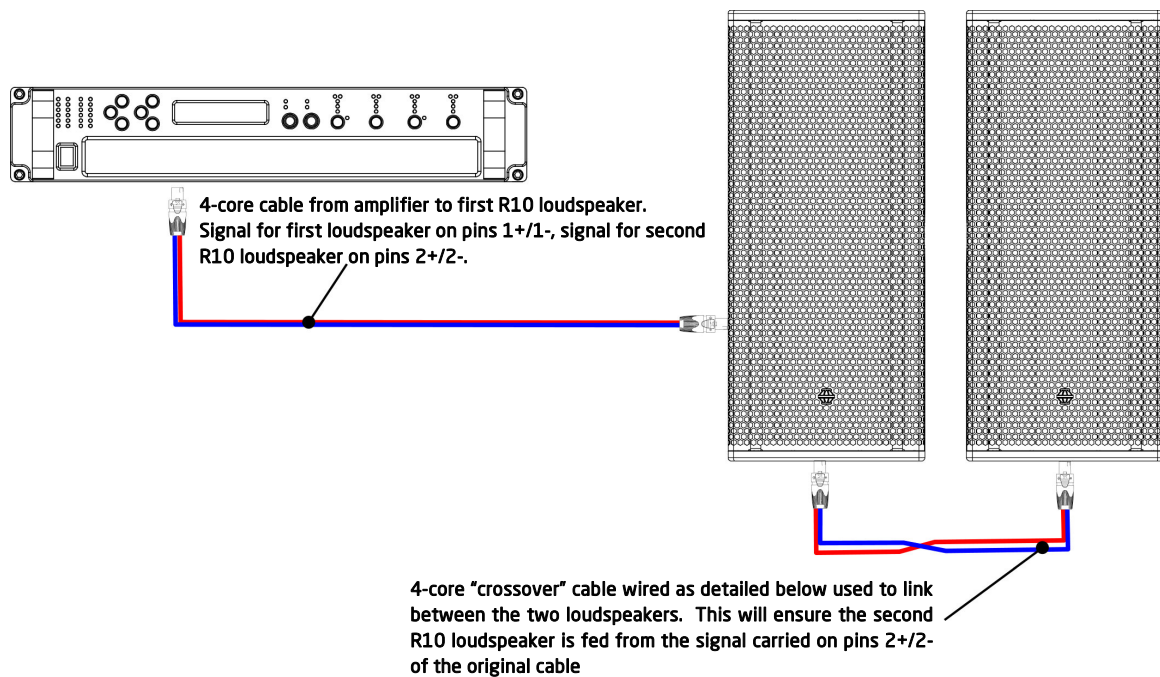

Crossover cable specifications

Connector A Pin	Connector B Pin
1+	2+
1-	2-
2+	1+
2-	1-

7.0 - Servicing Information

All R10 components can be removed for service purposes if required, using the minimum of tools.

7.1 - R10: Removing the grille

TOOLS REQUIRED: 4mm Allen key

1. Lie the enclosure on its' back and remove the two M6x30 countersunk socket screws from each end using a 4mm Allen key, and then lift the grille clear of the cabinet.

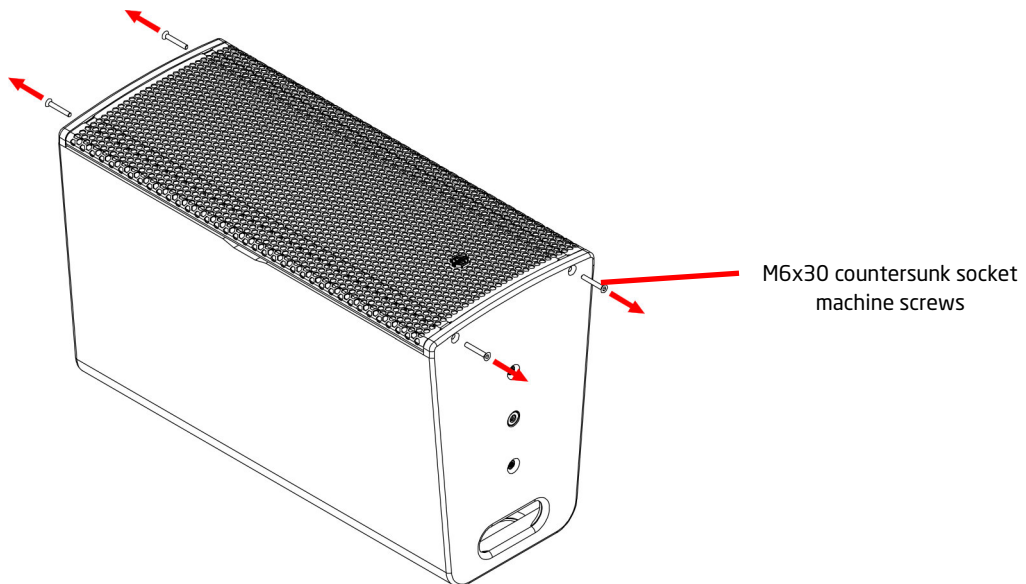

2. To replace the grille, position the grille on the front of the R10 and ensure the threaded fittings on the grille are lined up with the mounting holes - gentle pressure may be required. Replace all of the M6x30 countersunk socket screws and ensure they are all started in their threads before beginning to tighten. Ensure they are all tightened evenly so that the grille sits straight and does not rattle. Be careful not to over-tighten as this will distort the grille.

7.2 - R10: Removing the LF drive unit

TOOLS REQUIRED: 4mm & 5mm Allen keys

1. Complete step 7.1 above to remove the grille.
2. Using a 4mm Allen key, remove the two M6x35 button head socket screws that secure the MHF waveguide. Remove the waveguide from the enclosure and ensure that you collect both the spring and flat washers as well as the machine screws.

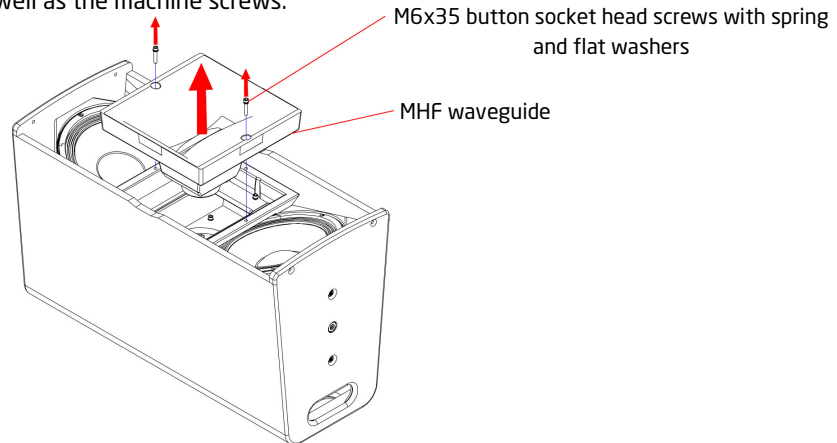

3. Using a 5mm Allen key, undo the four M6x30 socket cap bolts that secure the occlusion bowl to the enclosure. With these bolts removed, the occlusion bowl can be removed which will expose all the securing bolts for both 10" drive units.

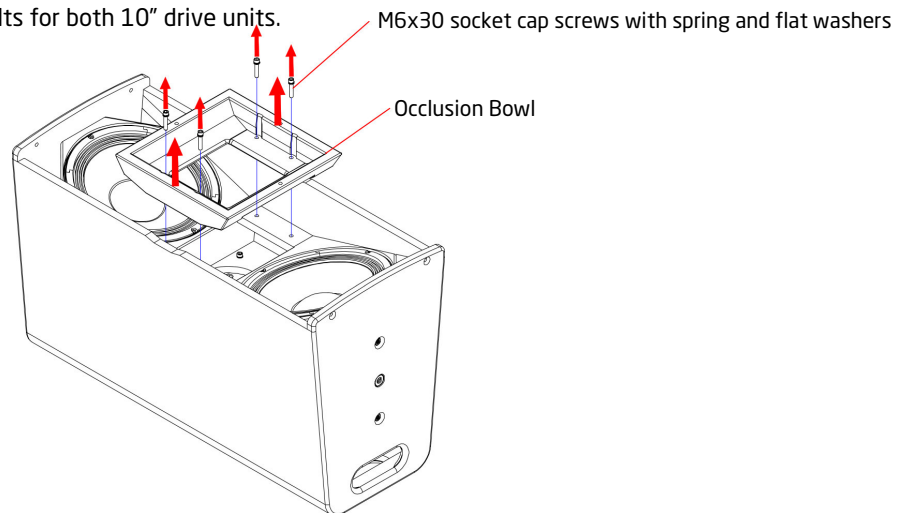

4. Using a 4mm Allen key, undo the four M5x30 socket cap bolts that secure the drive unit to want to remove. Ensure you remove the spring washer as well as each bolt, then lift the drive unit clear of the enclosure and disconnect the cables. Note the polarity for future reconnection - brown cable to the positive (red) driver terminal, blue cable to the negative (black) terminal.

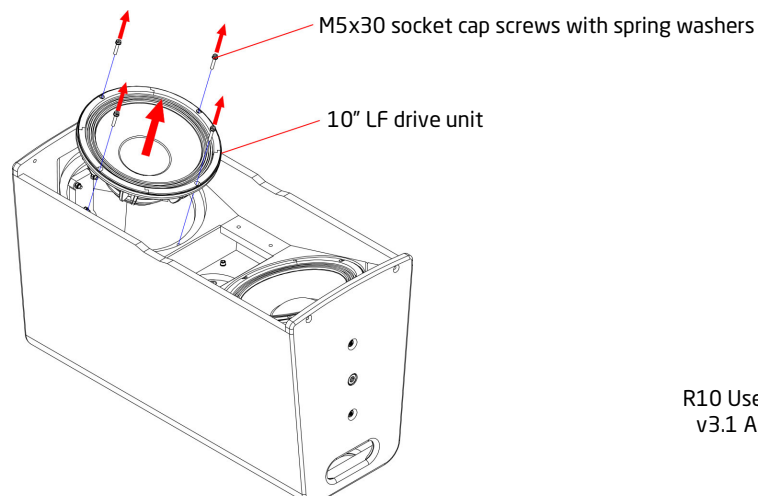

5. To replace the drive unit, ensure the 10" gasket is intact and complete - replace if necessary. Reconnect the cables to the drive unit (note the polarity detailed above) and then sit the drive unit into its mounting location, ensuring that the mounting holes line up.
6. Replace the M5x30 socket cap machine screws with their spring washers and ensure all machine screws are started in their threads before tightening. Tighten opposing bolts, working around the drive unit until all bolts are appropriately tightened. Be careful not to overtighten as this will distort the drive unit chassis.
7. Replace the occlusion bowl in the enclosure. Ensure it is the correct orientation - there are cutouts in the underside to account for the excursion of the 10" drive units. Replace the four M6 socket cap bolts (with their spring and flat washers) and start each bolt by hand, before tightening down to ensure the bowl is fixed in place.
8. Replace the waveguide into the enclosure - note that there is a precise fit at the throat of the waveguide with the aluminium mounting plate in the enclosure, so ensure this is located properly before attempting to retighten the bolts.
9. With the waveguide in the correct orientation, replace the M6x35 button head socket screws and retighten.
10. Replace the grille as described above.

7.3 - R10: Removing the HF drive unit

TOOLS REQUIRED: 4mm & 5mm Allen keys, TX30 Torx driver

1. Complete step 7.1 above to remove the grille, and step 7.2 above to remove the MHF waveguide, occlusion bowl and the **upper** 10" drive unit.
2. Reach in through the baffle hole for the 10" drive unit you have removed and disconnect the MF and HF output cables from the circuit board. Note the polarity for reconnection - red cable MF +, blue cable MF -, white cable HF +, yellow cable HF -. **It is strongly recommended to remove the cables from the circuit board rather than the drive unit as they are easier to reconnect to the drive unit outside of the loudspeaker enclosure.**
3. Reaching through the 10" baffle hole, support the rear of the MHF drive unit. Using a TX30 Torx drive bit, remove the four countersunk M6x10 Torx machine screws around the MHF drive unit exit to release it. It can then be removed through the LF drive unit hole.

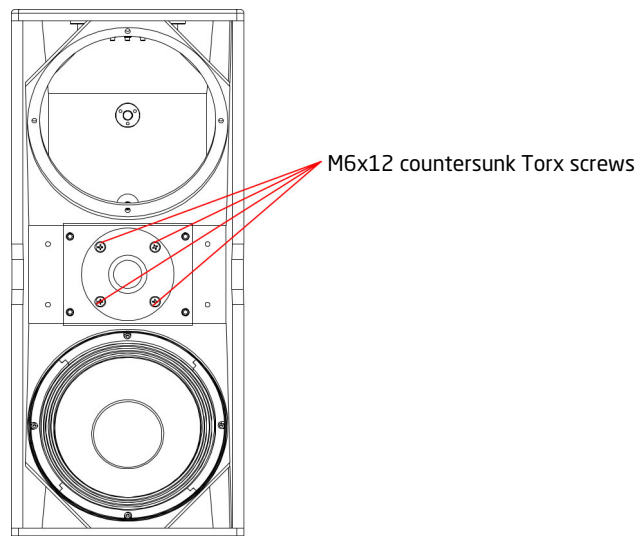

4. If changing the drive unit, be aware of the correct connections on the back of the MHF drive unit as shown below for reconnection:

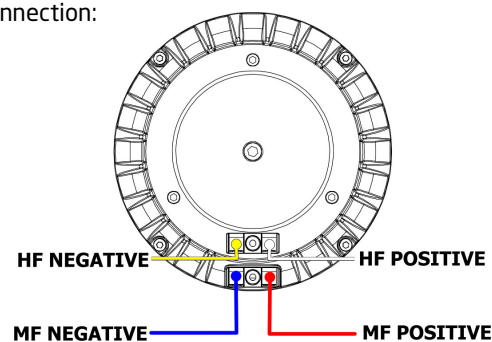

5. To reinstate the MHF drive unit, first check the cables are correctly connected and then insert it through the LF drive unit hole and hold against the aluminium mounting plate. Ensure that the cables present toward the top of the enclosure. Use the four M6x10 countersunk Torx machine screws to secure the drive unit and lock it in place.
6. Follow steps 5-10 in 7.2 above to replace the 10" LF drive unit, occlusion bowl, waveguide and grille.

Appendix A - Technical Specifications

R10 3-way precision passive point source loudspeaker

Dimensions (HxWxD):	700 x 306 x 430mm (27.6" x 12" x 16.9")	
Net/Shipping Weight:	31/36kg (68.2/79.2lbs)	
Frequency Response (+/- 3dB) ¹ :	60Hz - 20kHz	
Dispersion ³ :	80° x 50° rotatable (narrow waveguide) 110° x 50° rotatable (wide waveguide)	
Drive Units:	2 x 10" (254mm) neodymium LF drive unit 1.4" (36mm) exit neodymium MHF annular compression drive unit	
Power Handling:	1000W RMS, 2000W program	
Maximum SPL:	130dB continuous, 136dB peak	
Nominal Impedance:	8 ohms	
Crossover:	2-stage asymmetric internal passive	
Enclosures/channel (full SPL):	DQ6: 1 DQ10: 1 DQ20: 2	Di06: Not recommended Di10: Not recommended Di20: 1
Connectors:	2 x Neutrik SpeakON™ NL4	
Enclosure:	15mm (5/8") multi-laminate birch plywood, rebated, screwed and glued. Finished in impact and weather-resistant texyured polyurethane	
Rigging & Hardware:	Keyhole quick-release flying plate 2 x M10 threaded mounting points (1 top/1 bottom) 2 x M8 threaded safety point on rear 2 x M8 threaded safety point on top 2 x M8 threaded point on bottom for stand adapter 2 x flush handles Supplied with Reference Series stand adapter	
Grille:	Hex punched stainless steel backed with acoustically transparent fabric	
Options:	Colours/Weather Protection	
Accessories:	FC-R10v vertical flying cradle FC-R10h horizontal flying cradle VFA-R10 variable angle flying bracket Cradle stand adapter CASE-R10 dual enclosure touring flightcase	

Notes on measurement conditions:

¹Measured on-axis at 2m in an anechoic environment and referenced to 1m. ²Measured in half-space at 2m with 4W sine wave input and referenced to 1m. ³Nominal dispersion, measured in an anechoic environment and averaged over stated bandwidth. ⁴Calculated and verified by subjective listening test of familiar program material.

Appendix B - Technical Drawings

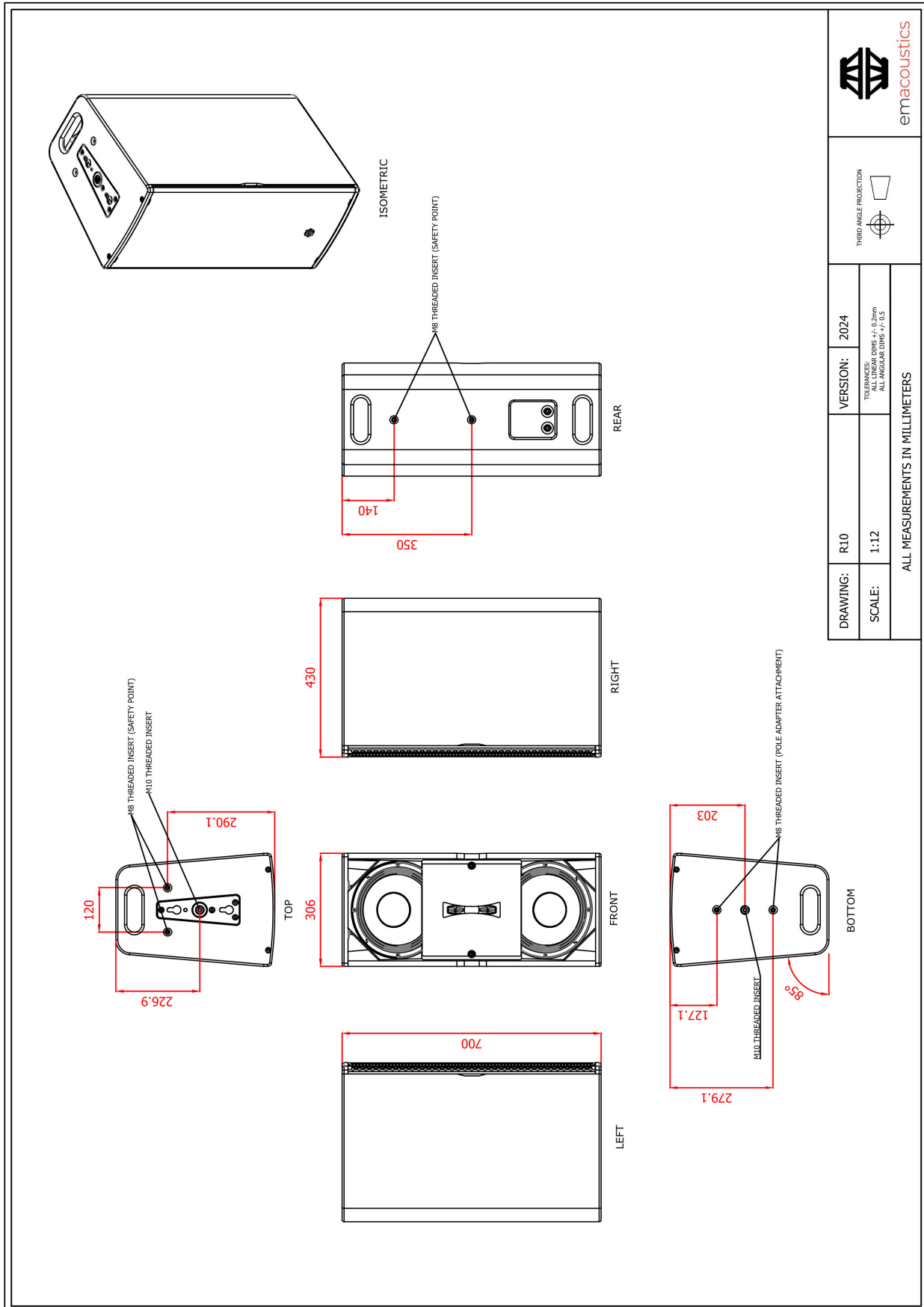

DRAWING:	R10	VERSION:	2024
	SCALE:	1:12	TOLERANCES: ALL DIMENSIONS ± 0.2mm ALL ANGLES 0.015 / 0.5
ALL MEASUREMENTS IN MILLIMETERS			



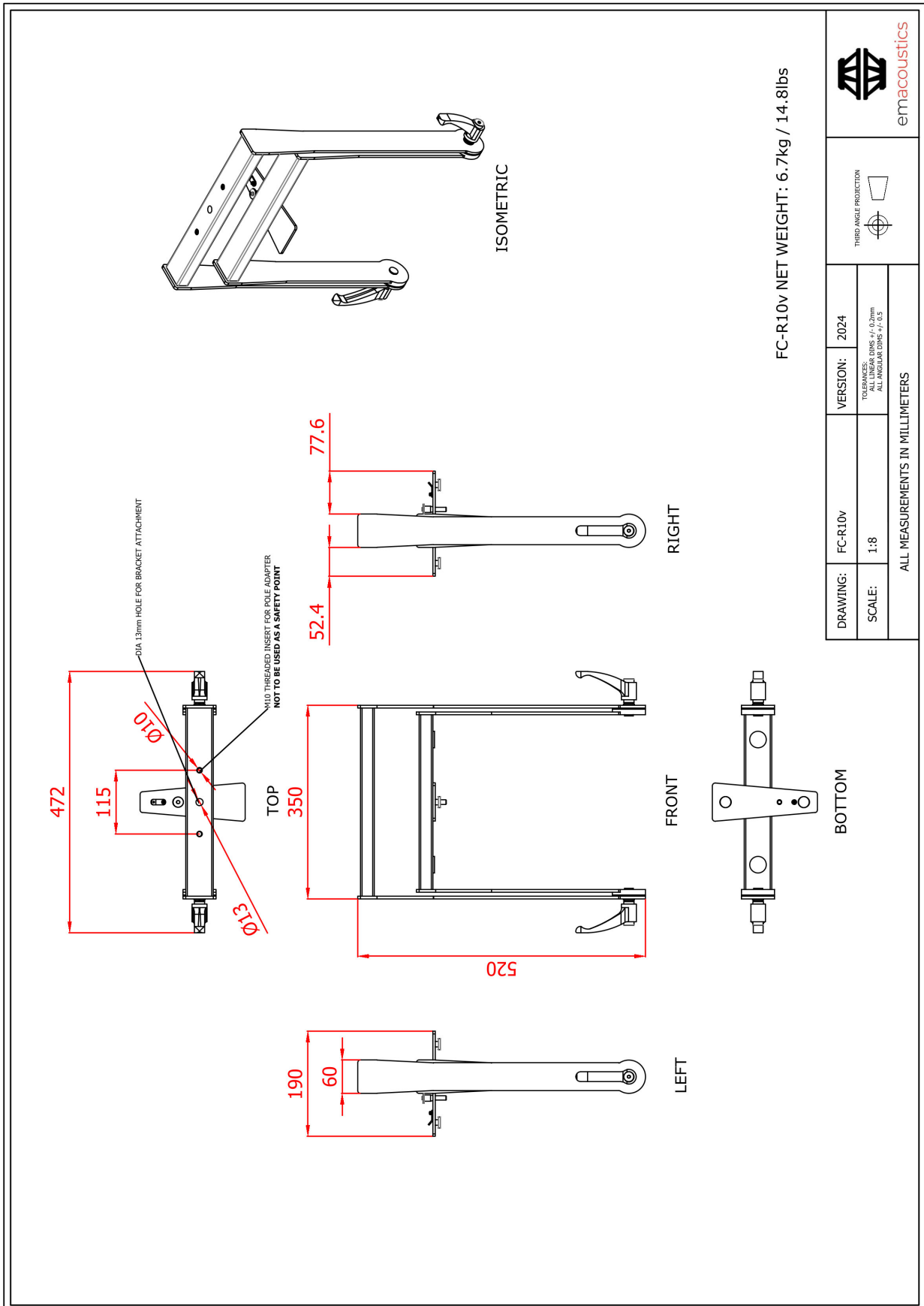

DRAWING:	FC-R10v	VERSION:	2024
SCALE:	1:8	TOLERANCES: DIMS: ± 0.2mm ALL ANGULAR DIMS: ± 0.5°	
ALL MEASUREMENTS IN MILLIMETERS			
THIRD ANGLE PROJECTION			
			emacoustics

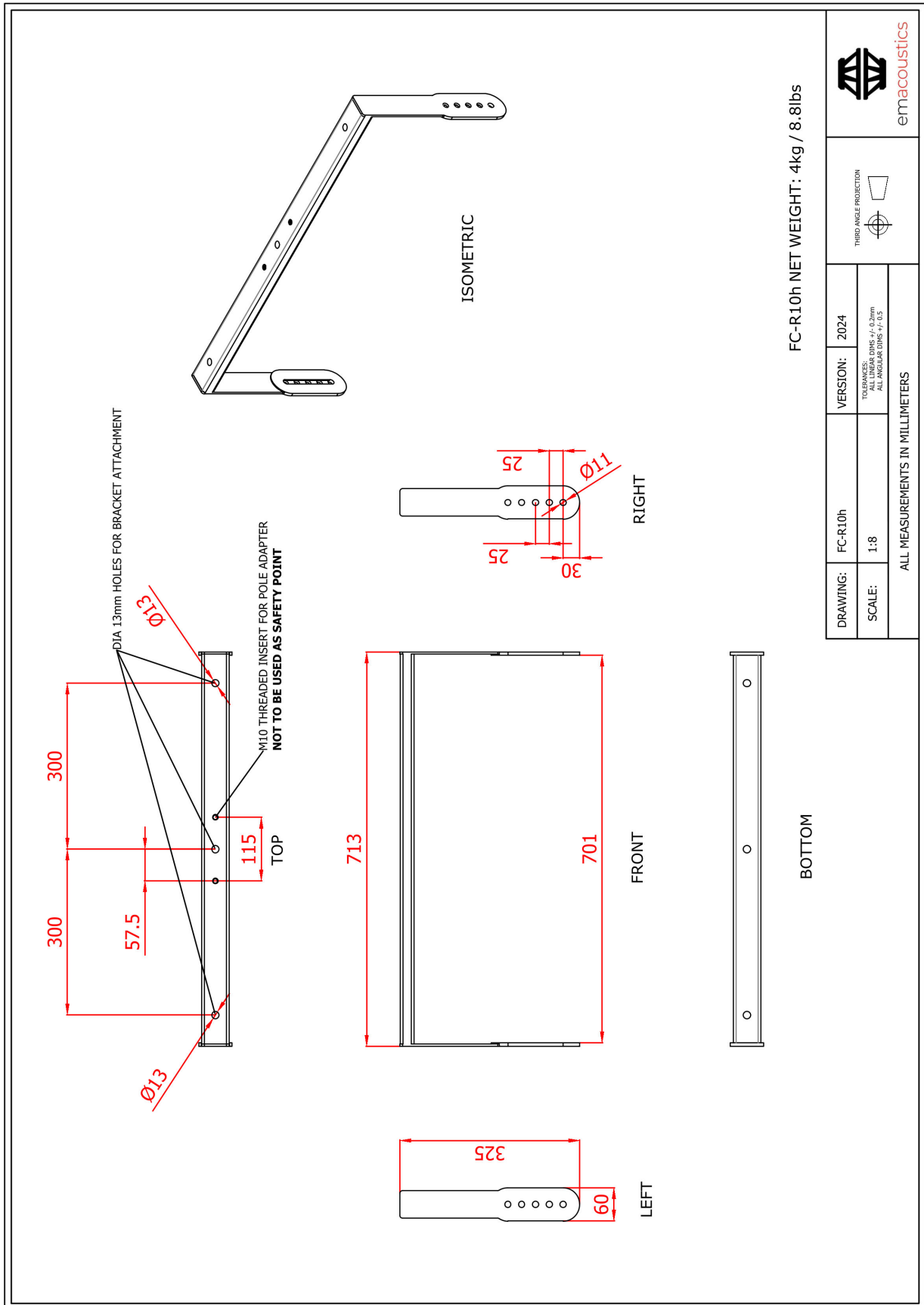

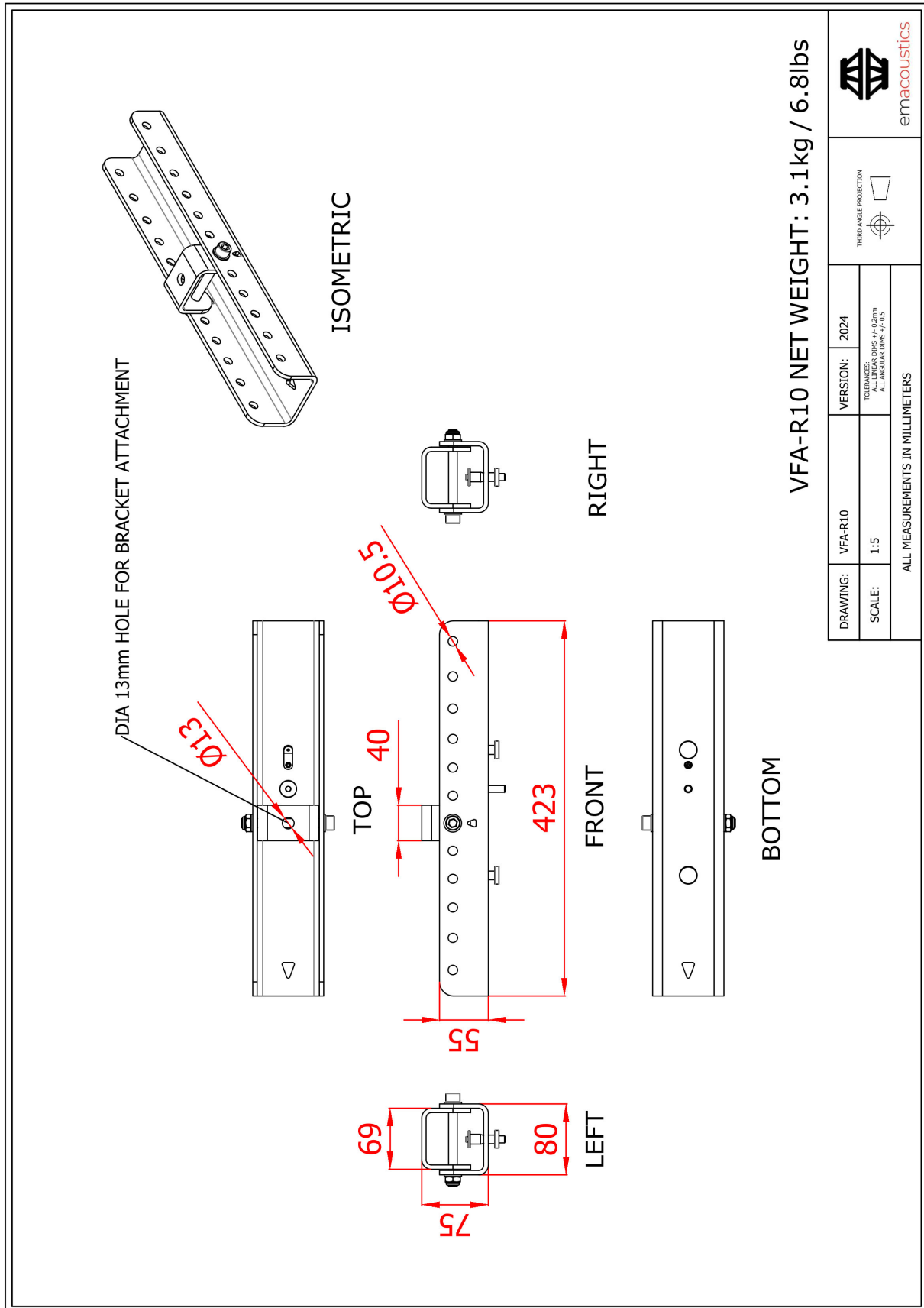

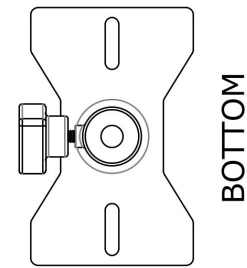
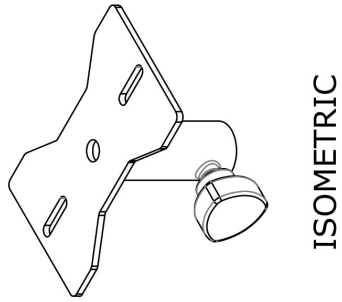
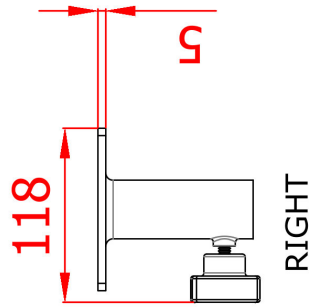
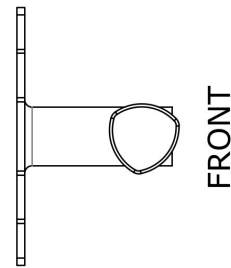
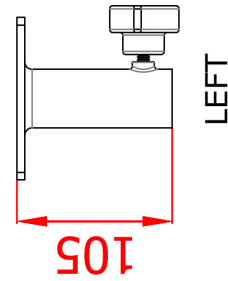
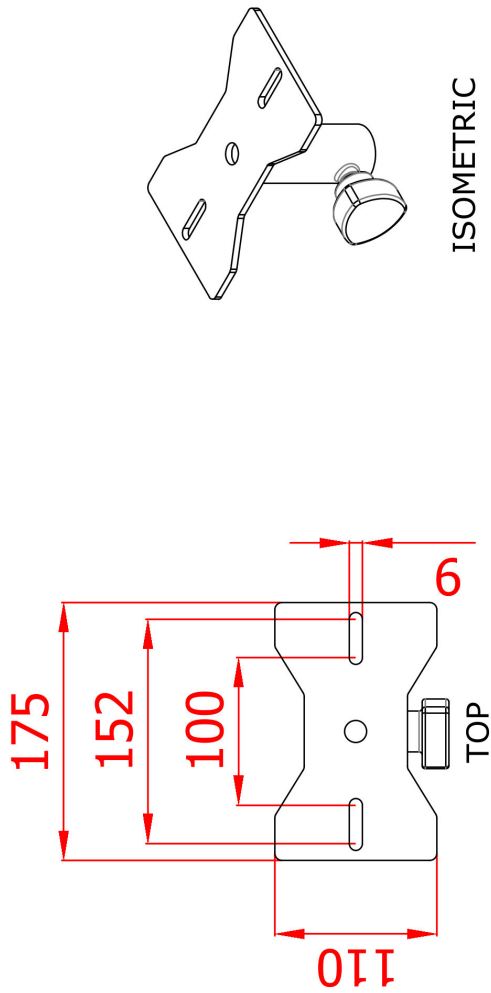

REFERENCE STAND ADAPTER NET WEIGHT: 0.75kg / 1.7lbs

DRAWING:	REF STAND ADAPTER	VERSION:	2024
SCALE:	1:4	TOLERANCES: DIMENSIONS: ± 0.2mm ALL ANGULAR DIMS: ± 0.5°	
ALL MEASUREMENTS IN MILLIMETERS			



emacoustics

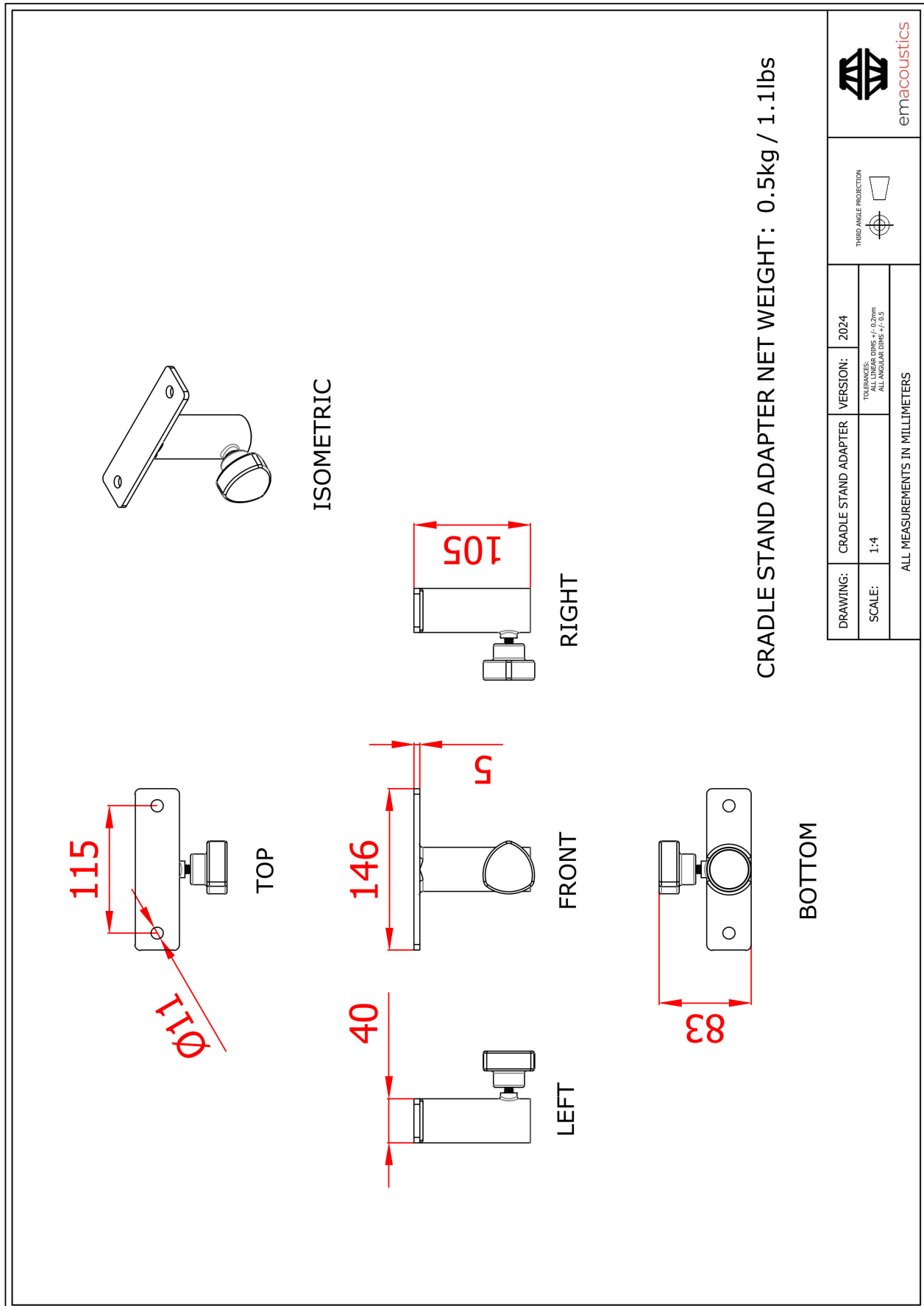

Appendix C - Spare Parts List

Order Code	Description
01A033	DU-1002-16 replacement 10" neodymium LF drive unit
01B018	CCD-1410 replacement 1.4" neodymium MHF compression drive unit
04A081	RFG-R10 replacement grille/fabric for R10
07A043	PX-R10-MHF replacement mid/high passive crossover assembly for R10
07A044	PX-R10-LF replacement low/mid passive crossover assembly for R10

Appendix D - Warranty Information

Limited Warranty

This EM Acoustics loudspeaker product is warranted to the original end-user purchaser and all subsequent owners for a period of **five (5) years** from the original date of purchase.

Warranty Coverage

This warranty covers defects in materials and workmanship. It does not include:

- Damage or failure caused by accident, misuse, neglect, abuse or modification by any person other than an authorised EM Acoustics representative.
- Damage or failure caused by operating the loudspeaker product contrary to the instructions contained within this manual.
- Damage caused during shipment.
- Claims based on any misrepresentation by the seller.
- Products which contain anything other than the original components (or EM Acoustics factory supplied spare parts).
- Products on which the serial number has been removed, altered or defaced.

Returning your EM Acoustics loudspeaker

Should your EM Acoustics loudspeaker develop a fault, please return it (freight prepaid) in its original packaging, along with proof of purchase to your local dealer or to:

EM Acoustics (Returns Department), Building 19.11, Dunsfold Park, Cranleigh, Surrey, GU6 8TB, UK

including a description of the suspected fault. Serial numbers must be quoted in all correspondence relating to the claim. EM Acoustics or its representatives are in no way liable for any loss or damage in transit, and hence it is recommended that the sender insure the shipment. EM Acoustics will pay for return freight should the repair be covered under warranty.

EM Acoustics' liability is to the replacement or repair (at our discretion) of any defective components, and as such are not liable for any incidental and consequential damages including (without limitation) injury to persons, damage to property or loss of use.

This warranty is exclusive and no other warranty is expressed or implied. This warranty is also in addition to - and in no way detracts from - your statutory rights as a consumer.