

DMX protocols

Compact DMX Mode

20 DMX channels

In Compact mode, the Backlight LEDs follow colors and intensity from the Beam LED (unless disabled using the Control/Settings channel).

Channel	DMX Value	Function	Fade type	Default value
1	0–19	Strobe/shutter Shutter closed	Snap	30
	20–49	Shutter open		
	50–200	Strobe (slow → fast)		
	201–210	Shutter open		
	211–255	Random strobe (slow → fast)		
2	0–65535	Dimmer Closed → Open	Fade	0
3				
4	0–65535	Red Intensity 0 → 100%	Fade	65535
5				
6				
7	0–65535	Green Intensity 0 → 100%	Fade	65535
8				
9	0–65535	Blue Intensity 0 → 100%	Fade	65535
10	0–38	CTC 2 000 K	Fade	128
	39	2 050 K		
		
	127	6 450 K		
	128	6 500 K		
	129	6 550 K		
...	...			
255	12 850 K			
11	0	Tint (Green Magenta Shift) $\Delta uv - 0.05$ (full shift towards magenta)	Fade	128
	1–126	$\Delta uv - 0.05 \rightarrow \Delta uv 0.00$		
	127–128	$\Delta uv 0.00$ (no shift - on black body curve)		
	129–254	$\Delta uv 0.00 \rightarrow \Delta uv + 0.05$		
	255	$\Delta uv + 0.05$ (full shift towards green)		
12	0–10	Virtual color wheel Solid colors Open	Snap	0
	11–12	Moroccan Pink (LEE 790)		
	13–14	Pink (LEE 157)		
	15–16	Special Rose Pink (LEE 332)		
	17–18	Follies Pink (LEE 328)		
	19–20	Fuchsia Pink (LEE 345)		
	21–22	Surprise Pink (LEE 194)		
	23–24	Congo Blue (LEE 181)		
	25–26	Tokyo Blue (LEE 071)		
	27–28	Deep Blue (LEE 120)		

	29–30 31–32 33–34 35–36 37–38 39–40 41–42 43–44 45–46 47–48 49–50 51–52 53–54 55–56 57–58 59–60 61–62 63–64 65–66 67–68 69–70 71–72 73–74 75–76 77–78 79–80 81–82 83–84 85–86 87–88 89–90 91–92 93–94 95–96 97–98 99–100 101–102 103–104 105–106 107–190 191–214 215–219 220–243 244–255	Just Blue (LEE 079) Medium Blue (LEE 132) Double CT Blue (LEE 200) Slate Blue (LEE 161) Full CT Blue (LEE 201) Half CT Blue (LEE 202) Steel Blue (LEE 117) Lighter Blue (LEE 353) Light Blue (LEE 118) Medium Blue Green (LEE 116) Dark Green (LEE 124) Primary Green (LEE 139) Moss Green (LEE 089) Fern Green (LEE 122) Jas Green (LEE 738) Lime Green (LEE 088) Spring Yellow (LEE 100) Deep Amber (LEE 104) Chrome Orange (LEE 179) Orange (LEE 105) Gold Amber (LEE 021) Millennium Gold (LEE 778) Deep Golden Amber (LEE 135) Flame Red (LEE 164) Red Magenta (LEE 113) Medium Lavender (LEE 343) Pure White (White LEDs only) Pure Red (Red LEDs only) Pure Yellow (Red + Green LEDs only) Pure Green (Green LEDs only) Pure Cyan (Green + Blue LEDs only) Pure Blue (Blue LEDs only) Pure Magenta (Blue + Red LEDs only) Peacock Blue (LEE 115) Dark Lavender (LEE 180) Double CT Orange (LEE 287) Full CT Orange (LEE 204) Half CT Orange (LEE 205) Deep Straw (LEE 015) No function Continuous rotation CW, fast → slow Stop (wheel stops at current color) CCW, slow → fast Random colors Fast → slow		
13	0–51400	Zoom Narrow → wide	Fade	25700
14	51401–57825 57826–59110 59111–65535	Pulse forward fast → slow Zoom stops at current position Pulse backward slow → fast		
15	0–65535	Pan Left → right	Fade	32768
16				
17	0–65535	Tilt Forward → backward	Fade	32768
18				

19	0–9	Fixture control / settings Exit calibration function (if active) and return to normal control	Snap	0
	10–14	Reset fixture – 5 sec.		
	15–16	<i>No function</i>		
	17	Reset Beam only – 5 sec.		
	18	Reset pan and tilt only – 5 sec.		
	19–22	<i>No function</i>		
	23	Linear dimmer curve – 1 sec.		
	24	Square law dimmer curve (default) – 1 sec.		
	25	Inverse square law dimmer curve – 1 sec.		
	26	S-Curve dimmer curve – 1 sec.		
	27	Pan and tilt speed = Standard – 1 sec.		
	28	Pan and tilt speed = Fast (default) – 1 sec.		
	29	Pan and tilt speed = Smooth – 1 sec.		
	30–35	<i>No function</i>		
	36	Video tracking = ON – 1 sec.		
	37	Video tracking = OFF (default) – 1 sec.		
	38	Extended color Mode (default) – 1 sec.		
	39	Calibrated color Mode – 1 sec.		
	40–51	<i>No function</i>		
	52	Control panel display = ON (default) – 1 sec.		
	53	Control panel display = OFF – 1 sec.		
	54	Regulated fan speed, fixed output intensity (default) – 1 sec.		
	55	Full fan speed, regulated output intensity – 1 sec.		
	56	Medium fan speed, regulated output intensity – 1 sec.		
	57	Low fan speed, regulated output intensity – 1 sec.		
	58	Ultra-low fan speed, regulated light output intensity – 1 sec.		
	59–60	<i>No function</i>		
	61	Hibernation Mode = ON – 1 sec.		
	62	Hibernation Mode = OFF (default) – 1 sec.		
	63–64	<i>No function</i>		
	65	Pan and tilt limits = ON – 1 sec.		
	66	Pan and tilt limits = OFF (default) – 1 sec.		
	67	Store lower pan limit – 1 sec.		
	68	Store upper pan limit – 1 sec.		
	69	Store lower tilt limit – 1 sec.		
70	Store upper tilt limit – 1 sec.			
71	Reset pan and tilt limits – 1 sec.			
72	Tungsten emulation = ON – 1 sec.			
73	Tungsten emulation = OFF (default) – 1 sec.			
74	Scene capture record – 5 sec.			
75	Scene capture Standalone = ON – 5 sec.			
76	Scene capture Standalone = OFF (default) – 5 sec.			
77–91	<i>No function</i>			
92	Compact mode backlight = ON – 1 sec.			
93	Compact mode backlight = OFF (default) – 1 sec.			
94–99	<i>No function</i>			
100	Enable calibration adjustment – 5 sec.			
101	Store pan and tilt calibration – 5 sec.			
102	Store dimmer calibration – 5 sec.			
103–113	<i>No function</i>			

	114 115–198 199 200–255	Store zoom calibration – 5 sec. <i>No function</i> Reset ALL calibrations to factory defaults – 5 sec. <i>No function</i>		
20	0 1–127 128 129–254 255	LED PWM frequency Hybrid LED dimming mode Variable -2% – 0% 2400 Hz Variable 0% – +2% <i>No function</i>	Fade	128

Basic DMX Mode

36 DMX channels

Channel	DMX Value	Function	Fade type	Default value
<i>Channels 1–20 as in Compact Mode</i>				
Beam control				
21	0–26	Beam P3 Mix DMX Mode Pure DMX control, P3 pixels are ignored	Snap	0
	27	Mix Mode Pure DMX control, P3 pixels are ignored		
	27–228	Crossfade DMX → P3 pixel control		
	228	Pure P3 pixel control		
229–255	Video Mode P3 with DMX overlay (DMX channels "color" the P3 pixel data)			
22	0–255	FX 1 (see table below) FX selection 1–255	Snap	0
23	0–126	FX 1 adjust Reverse fast → slow	Snap	128
	127–129	Stop		
	130–255	Slow → fast		
24	0–255	FX 2 (see table below) FX selection 1–255	Snap	0
25	0–126	FX 2 adjust Reverse fast → slow	Snap	128
	127–129	Stop		
	130–255	Slow → fast		
26	0	FX Synchronization No sync	Snap	36
	1	Offset shift 10°		
	2–34	Offset shift 20°–340°		
	35	Offset shift 350°		
	36	Synchronized (all fixtures start FX cycles at same time)		
	37–100	<i>No function</i>		
	101–120	Random FX cycle start		
121–140	Random FX cycle duration			
141–255	<i>No function</i>			

Backlight control (all LEDs controlled together)				
27	0–19 20–49 50–200 201–210 211–255	Backlight strobe/shutter Shutter closed Shutter open Strobe slow → fast Shutter open Random strobe slow → fast	Snap	30
28	0–65535	Backlight dimmer Closed → Open	Fade	0
29				
30	0–255	Backlight Red Intensity 0 → 100%	Fade	255
31	0–255	Backlight Green Intensity 0 → 100%	Fade	255
32	0–255	Backlight Blue Intensity 0 → 100%	Fade	255
33	0–38 39 ... 127 128 129 ... 255	Backlight CTC 2 000 K 2 050 K ... 6 450 K 6 500 K 6 550 K ... 12 850 K	Fade	128
34	0 1–126 127–128 129–254 255	Backlight Tint (Green-Magenta Shift) $\Delta uv - 0.05$ (full shift towards magenta) $\Delta uv - 0.05 \rightarrow \Delta uv 0.00$ $\Delta uv 0.00$ (no shift - on black body curve) $\Delta uv 0.00 \rightarrow \Delta uv + 0.05$ $\Delta uv + 0.05$ (full shift towards green)	Fade	128
35	0–10 11–12 13–14 15–16 17–18 19–20 21–22 23–24 25–26 27–28 29–30 31–32 33–34 35–36 37–38 39–40 41–42 43–44 45–46 47–48 49–50 51–52 53–54	Backlight virtual color wheel Solid colors Open Moroccan Pink (LEE 790) Pink (LEE 157) Special Rose Pink (LEE 332) Follies Pink (LEE 328) Fuchsia Pink (LEE 345) Surprise Pink (LEE 194) Congo Blue (LEE 181) Tokyo Blue (LEE 071) Deep Blue (LEE 120) Just Blue (LEE 079) Medium Blue (LEE 132) Double CT Blue (LEE 200) Slate Blue (LEE 161) Full CT Blue (LEE 201) Half CT Blue (LEE 202) Steel Blue (LEE 117) Lighter Blue (LEE 353) Light Blue (LEE 118) Medium Blue Green (LEE 116) Dark Green (LEE 124) Primary Green (LEE 139) Moss Green (LEE 089)	Snap	0

	55–56 57–58 59–60 61–62 63–64 65–66 67–68 69–70 71–72 73–74 75–76 77–78 79–80 81–82 83–84 85–86 87–88 89–90 91–92 93–94 95–96 97–98 99–100 101–102 103–104 105–106 107–190 191–214 215–219 220–243 244–255	Fern Green (LEE 122) Jas Green (LEE 738) Lime Green (LEE 088) Spring Yellow (LEE 100) Deep Amber (LEE 104) Chrome Orange (LEE 179) Orange (LEE 105) Gold Amber (LEE 021) Millennium Gold (LEE 778) Deep Golden Amber (LEE 135) Flame Red (LEE 164) Red Magenta (LEE 113) Medium Lavender (LEE 343) Pure White (White LEDs only) Pure Red (Red LEDs only) Pure Yellow (Red + Green LEDs only) Pure Green (Green LEDs only) Pure Cyan (Green + Blue LEDs only) Pure Blue (Blue LEDs only) Pure Magenta (Blue + Red LEDs only) Peacock Blue (LEE 115) Dark Lavender (LEE 180) Double CT Orange (LEE 287) Full CT Orange (LEE 204) Half CT Orange (LEE 205) Deep Straw (LEE 015) No function Continuous rotation CW, fast → slow Stop (wheel stops at current color) CCW, slow → fast Random colors Fast → slow		
36	0–26 27 27–228 228 229–255	Backlight P3 Mix DMX Mode Pure DMX control, P3 pixels are ignored Mix Mode Pure DMX control, P3 pixels are ignored Crossfade DMX → P3 pixel control Pure P3 pixel control Video Mode P3 with DMX overlay (DMX channels "color" the P3 pixel data)	Snap	0

Ludicrous DMX Mode

108 DMX channels

Channel	DMX Value	Function	Fade type	Default value
<i>Channels 1–36 as in Basic Mode</i>				
<i>Backlight RGB (channels 30-32) is merged with backlight pixel control (channels 37-108) using HTP.</i>				
37	0–255	Backlight Pixel 1 Red 0 → 100%	Fade	0
38	0–255	Backlight Pixel 1 Green 0 → 100%	Fade	0
39	0–255	Backlight Pixel 1 Blue 0 → 100%	Fade	0
...		
106	0–255	Backlight Pixel 24 Red 0 → 100%	Fade	0
107	0–255	Backlight Pixel 24 Green 0 → 100%	Fade	0
108	0–255	Backlight Pixel 24 Blue 0 → 100%	Fade	0

Pixel mapping in Ludicrous Mode

Ludicrous DMX mode gives individual control of the Backlight pixels. These are numbered as shown in the drawing on the right with the fixture in hanging orientation, pan at 50% and display and connectors at back of fixture.

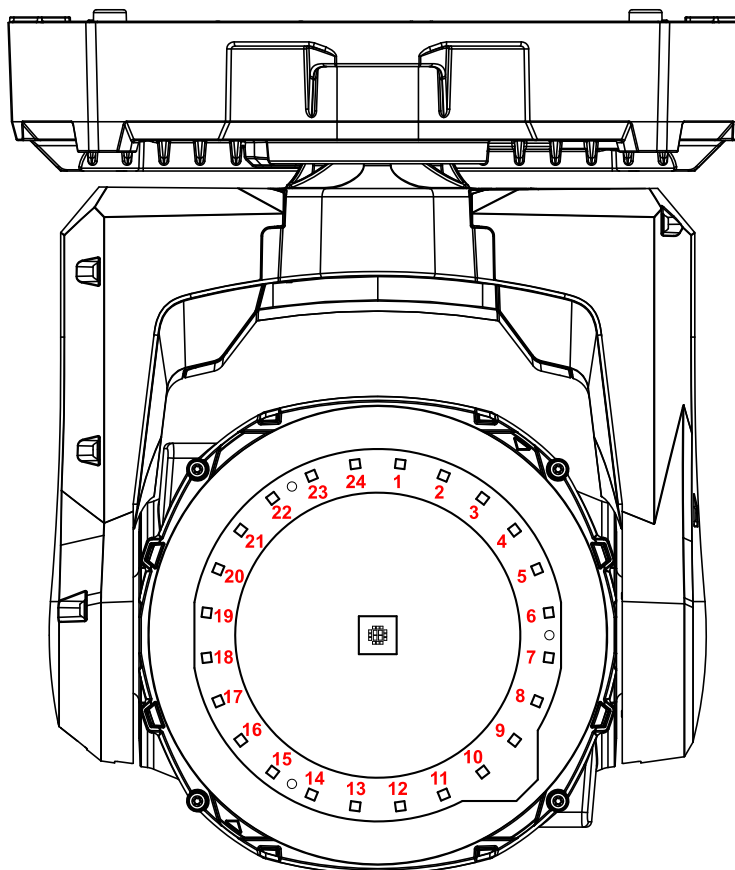

MAC One Backlight pixel layout

Compact Direct DMX Mode

20 DMX channels

In Compact Direct mode, the Backlight LEDs follow colors and intensity from the Beam LED (unless disabled via the Control/Settings channel).

Channel	DMX Value	Function	Fade type	Default value
1	0–19	Beam strobe/shutter Shutter closed	Snap	30
	20–49	Shutter open		
	50–200	Strobe slow → fast		
	201–210	Shutter open		
	211–255	Random strobe slow → fast		
2	0–65535	Beam dimmer Closed → Open	Fade	0
3				
4	0–65535	Beam Red Intensity 0 → 100%	Fade	65535
5				
6	0–65535	Beam Green Intensity 0 → 100%	Fade	65535
7				
8	0–65535	Beam Blue Intensity 0 → 100%	Fade	65535
9				
10	0–65535	Beam Lime Intensity 0 → 100%	Fade	65535
11				
12	No function			
13	0–51400 51401–57825	Zoom Narrow → wide	Fade	25700
14		Pulse forward fast → slow Zoom stops at current position Pulse backward reverse slow → fast		
15	0–65535	Pan Left → right	Fade	32768
16				
17	0–65535	Tilt Forward → backward	Fade	32768
18				
19	0–9	Fixture control / settings Exit calibration function (if active) and return to normal control	Snap	0
	10–14	Reset fixture – 5 sec.		
	15–16	<i>No function</i>		
	17	Reset Beam only – 5 sec.		
	18	Reset pan and tilt only – 5 sec.		
	19–22	<i>No function</i>		
	23	Linear dimmer curve – 1 sec.		
	24	Square law dimmer curve (default) – 1 sec.		
	25	Inverse square law dimmer curve – 1 sec.		
	26	S-Curve dimmer curve – 1 sec.		
	27	Pan and tilt speed = Standard – 1 sec.		
	28	Pan and tilt speed = Fast (default) – 1 sec.		
	29	Pan and tilt speed = Smooth – 1 sec.		

	<p>30–35 36 37 38 39 40–51 52 53 54 55 56 57 58 59–60 61 62 63–64 65 66 67 68 69 70 71 72 73 74 75 76 77–91 92 93 94–99 100 101 102 103–113 114 115–198 199 200–255</p>	<p><i>No function</i> Video tracking = ON – 1 sec. Video tracking = OFF (default) – 1 sec. Extended color Mode (default) – 1 sec. Calibrated color Mode – 1 sec. <i>No function</i> Control panel display = ON (default) – 1 sec. Control panel display = OFF – 1 sec. Regulated fan speed, fixed output intensity (default) – 1 sec. Full fan speed, regulated output intensity – 1 sec. Medium fan speed, regulated output intensity – 1 sec. Low fan speed, regulated output intensity – 1 sec. Ultra-low fan speed, regulated light output intensity – 1 sec. <i>No function</i> Hibernation Mode = ON – 1 sec. Hibernation Mode = OFF (default) – 1 sec. <i>No function</i> Pan and tilt limits = ON – 1 sec. Pan and tilt limits = OFF (default) – 1 sec. Store lower pan limit – 1 sec. Store upper pan limit – 1 sec. Store lower tilt limit – 1 sec. Store upper tilt limit – 1 sec. Reset pan and tilt limits – 1 sec. Tungsten emulation = ON – 1 sec. Tungsten emulation = OFF (default) – 1 sec. Scene capture record – 5 sec. Scene capture Standalone = ON – 5 sec. Scene capture Standalone = OFF (default) – 5 sec. <i>No function</i> Compact mode backlight = ON – 1 sec. Compact mode backlight = OFF (default) – 1 sec. <i>No function</i> Enable calibration adjustment – 5 sec. Store pan and tilt calibration – 5 sec. Store dimmer calibration – 5 sec. <i>No function</i> Store zoom calibration – 5 sec. <i>No function</i> Reset ALL calibrations to factory defaults – 5 sec. <i>No function</i></p>		
20	<p>0 1–127 128 129–254 255</p>	<p>LED PWM frequency Hybrid LED dimming mode Variable -2% – 0% 2400 Hz Variable 0% – +2% <i>No function</i></p>	Fade	128