

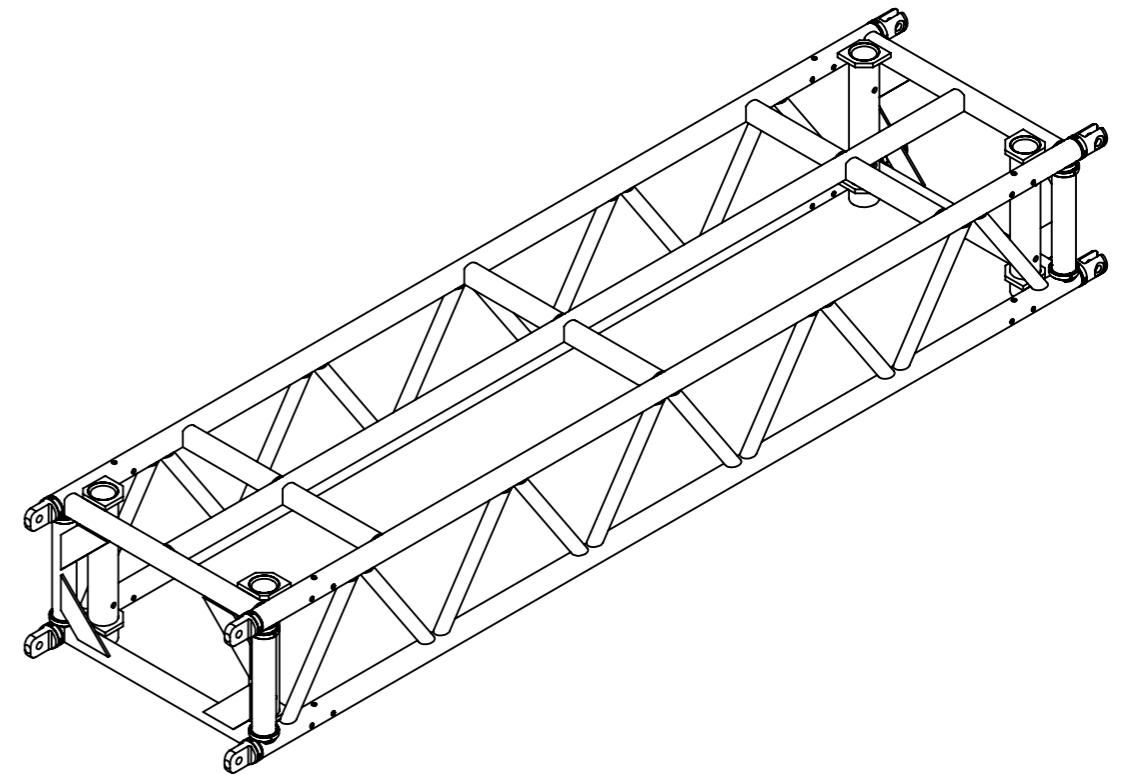

Weitergabe sowie Vervielfältigung dieses Dokuments, Verwertung und Mitteilung seines Inhalts sind verboten, soweit nicht ausdrücklich gestattet. Zuwiderhandlungen verpflichten zu Schadensersatz. Alle Rechte für den Fall der Patent-, Gebrauchsmuster- oder Designeintragung vorbehalten.  
 The reproduction, distribution and utilization of this document as well as the communication of its contents to others without express authorization is prohibited. Offenders will be held liable for the payment of damages. All rights reserved in the event of the grant of a patent, utility model or design.

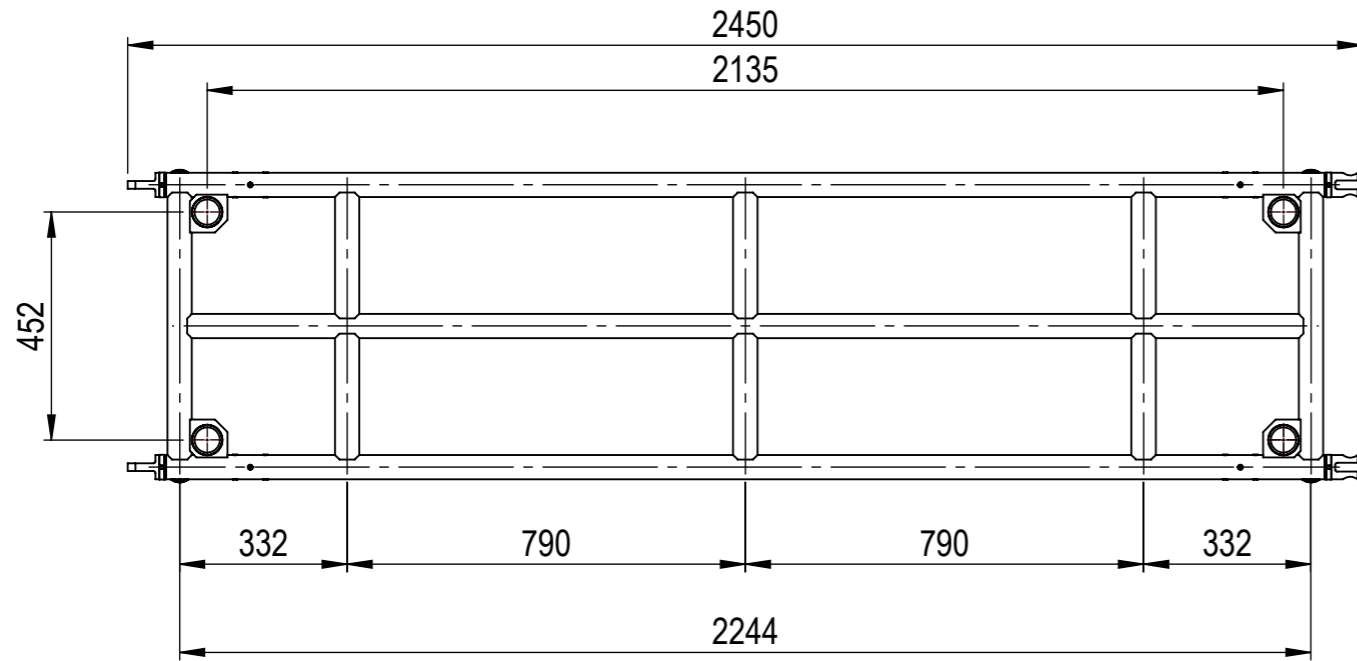
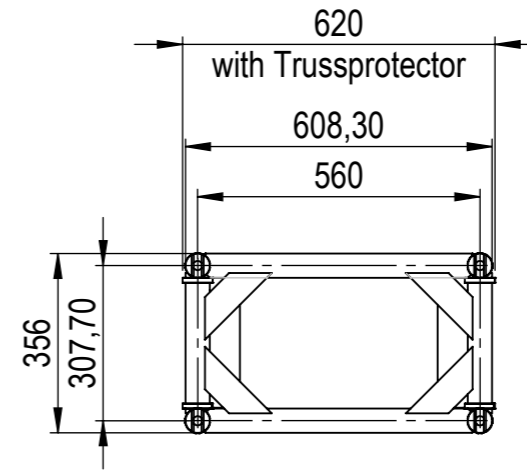
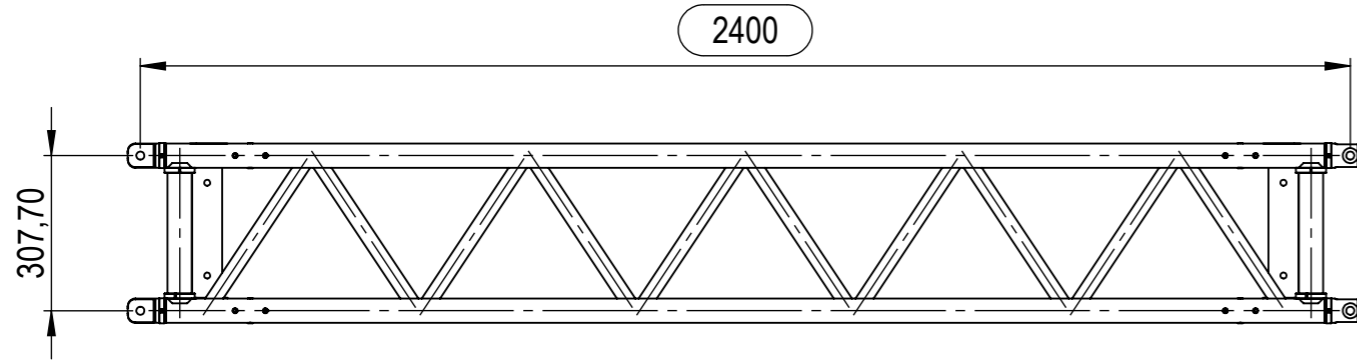

general tolerances for lengths: DIN ISO 2768-1								
precision	dimensions in mm for nominal dimension							
	0,5	> 3	> 6	> 30	> 120	> 400	> 1000	> 2000
... 3	... 6	... 30	... 120	... 400	... 1000	... 2000	... 4000	
m (medium)	± 0.1	± 0.1	± 0.2	± 0.3	± 0.5	± 0.8	± 1.2	± 2

ZUBEHÖR		
Bezeichnung	Menge	Artikelnummer
HOFFork 350/620 Trusspin HACKA	4	1139919
Federstecker	4	1119927
Trussprotector black 48-52mm	4	1582911

 H.O.F. Alutec Metallverarbeitungen GmbH & Co. KG Brookstraße 8 49497 Mettingen	UNLESS OTHERWISE DEFINED: TOLERANCES ACCORDING TO DIN 2768-1 m		STATUS: In Korrektur		WEIGHT: 50.84 kg	
	DEBUR AND BREAK SHARP EDGE		MATERIAL: EN-AW-6082 T6 (Schwarz gepulvert)		SURFACE: Pulverbeschichtung 9005 Tiefschwarz seidenmatt	
	DATE	NAME	TITLE:			
	DRAWN 28.05.18		HOFFORK MLT Two 2400mm			
CHECK:		DRAWING NUMBER:		DOCUMENT NUMBER:		
PROJECT NAME:		HOFFork MLT Pro 2400		HOFFork MLT Pro 2400		
PROJECT NUMBER:		ITEM NUMBER:		REVISION	SCALE: 1:15	
00	3mm Löcher entfernt	23.11.22	MZ	113350MLT22400BK	01	A3
01	Fork connectors changed	01.02.23	TK	LAST SAVED: 12.01.2024		
REV.	MODIFICATION	DATE	NAME	ORIGIN:		
				3		